

- CE marked curtain type fire damper
- Assessed against the requirements of BS EN 15650
- Four installation methods all with 120 minute 'E' ratings
- Galvanised steel construction as standard, stainless steel optional
- Vertical installations for masonry walls and drywall partitions
- Horizontal installation for concrete floor slabs
- Available to suit square, rectangular, circular and flat oval ducting
- Now available with fixing lugs

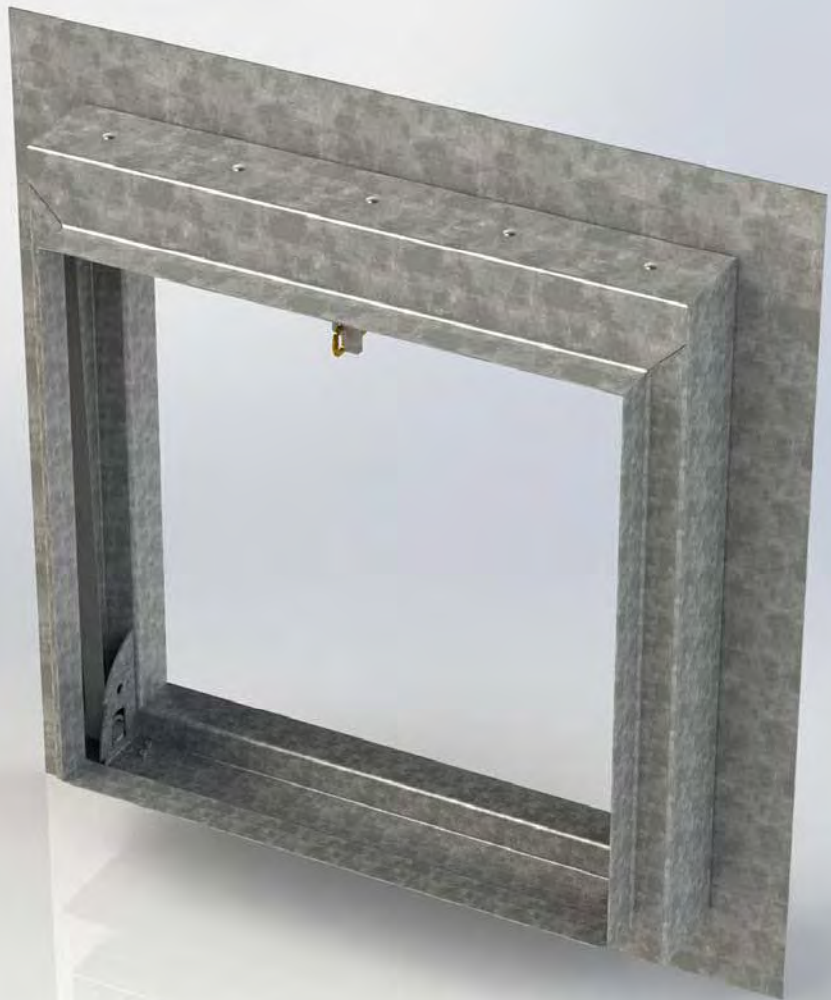

Index

Introduction

- 3 - CE marking
- 4 - Product overview and features
- 5 - Damper design

Testing and certification

- 6 - CE qualifying certification and corrosion testing
- 7 - Case leakage testing

CE marked installations

- 8 - Installation guide
- 9 - Installation FD-1V
HEVAC frame for masonry walls
Vertical installation with 120 minute 'E' rating
- 10 - Installation FD-2VP
Plate frame for drywall partitions
Vertical installation with 120 minute 'E' rating
- 11 - Installation FD-2VM
Plate frame for masonry walls
Vertical installation with 120 minute 'E' rating
- 12 - Installation FD-2HC
Plate frame for concrete floors
Horizontal installation with 120 minute 'E' rating
- 13 - Guide: Why is it so important to use certified fire dampers?

Dimensions

- 14 - Dimensions with HEVAC frame
- 15 - Dimensions with plate frame

Damper options

- 16 - Installation accessories, operation methods and maintenance assisting options
- 17 - Status indicators

Further information

- 18 - Installation and maintenance
Important note - Installation into chlorinated environments
- 19 - EC Declaration of Performance
- 19 - Finish details

Quality assurance

HVC Supplies (Stourbridge) Ltd is an ISO 9001 certified company.



Assessed to ISO 9001
Cert/Ref No. 1186

CE marking



In accordance with the Construction Products Regulation or CPR (305/2011/EU) introduced into the UK on the 1st of July 2013, any fire dampers sold into the UK and EU markets must be CE marked.

To obtain CE marking, companies and fire dampers themselves must fully comply with the requirements of BS EN 15650.

Companies must be:

- ISO 9001 accredited
- Monitoring production through a program of Factory Production Control (FPC)
- Issued with a certificate of constancy of performance by a notified body

Fire dampers must be:

- Fire tested to BS EN 1366-2
- Classified to BS EN 13501-3
- Thermal release mechanism tested to ISO 10294-4
- Stainless steel and multiple damper assemblies assessed against EN 15882-2

- HEVAC frame in a masonry wall
- Plate frame in a drywall partition
- Plate frame in a masonry wall
- Plate frame in a concrete floor

It is a legal requirement that fire dampers are installed in the way instructed by the manufacturer. Any other installation is untested and therefore illegal.

Responsibility for ensuring correct installation lies with all parties in the supply chain.

This brochure gives a short overview of the installation methods.

NCA Series 100 fire dampers

A CE marked fire damper, comprising a folding curtain type blade design.

Constructed from galvanised steel as standard, with stainless steel optional, and available with 120 minute 'E' rated installations to suit masonry walls, drywall partitions and concrete floors.

During normal conditions, the curtain type blade pack is recessed into the damper header and retained in place by a fusible link, leaving the duct open to airflow.

Upon exposure to temperatures exceeding the temperature rating of the fusible link, the link will split, and the blade pack will be fully extended by springs to shut down the duct.

Series 100 fire dampers are designed to be used as part of building compartmentalisation, this being the process of constructing a building with zones. The purpose of this is that if a fire starts in any one zone, it is contained within that zone and not allowed to spread, thereby potentially saving lives, limiting damage to the building and making the job of fire fighters easier.

It is useful to think of fire dampers as the ductwork equivalent of fire doors, allowing an unrestricted flow of air during normal operation, but shutting down a potential transmission route in the event of fire.



Design features

Material	Standard: Blades, frame, case and motor mounting plate - Galvanised steel Brass fusible link Optional: Stainless steel blades and / or case. Please contact us for more information.
Sizes	Minimum: 100mm x 100mm / 100mm diameter nominal Maximum: Damper in HEVAC frame - 1250mm x 1000mm / 1000mm diameter nominal Damper in plate frame - 1000mm x 1000mm / 1000mm diameter nominal (up to 1250mm x 1000mm with reduced time rating, please see page 8 for more information) Units above the maximum size can be made in multiple sections. Please contact us for more information.
Finish	Bare metal
Mass/m² face area	20 kg (S100BGH - 1000mm x 1000mm nominal size) 25 kg (S100CGH - 1000mm diameter nominal size) Smaller units will be proportionally heavier relative to size

Damper design

- 1. Installation frame**
Designed to integrate the damper into the partition. Available as a HEVAC (shown) or plate frame.
- 2. Link bracket**
Retains the fusible link.
- 3. Fusible link**
Retains the blade pack in a recessed position under normal conditions. Splits into two parts to release blades upon reaching rated temperature.
- 4. Blade pack**
Interlocking steel blades which concertina into the header during normal operation. When the fusible link splits the blade pack is pulled closed by the blade springs.
- 5. Case**
The main body of the damper, comprising elements including the header and spigots.
- 6. Lock guide**
Two fitted to each damper, act to retain the blade springs, and also lock the blade pack in position when closed.
- 7. Blade spring**
Fully extended during normal operation. When the fusible link splits, the blade springs pull the blade pack down and into the lock guides.

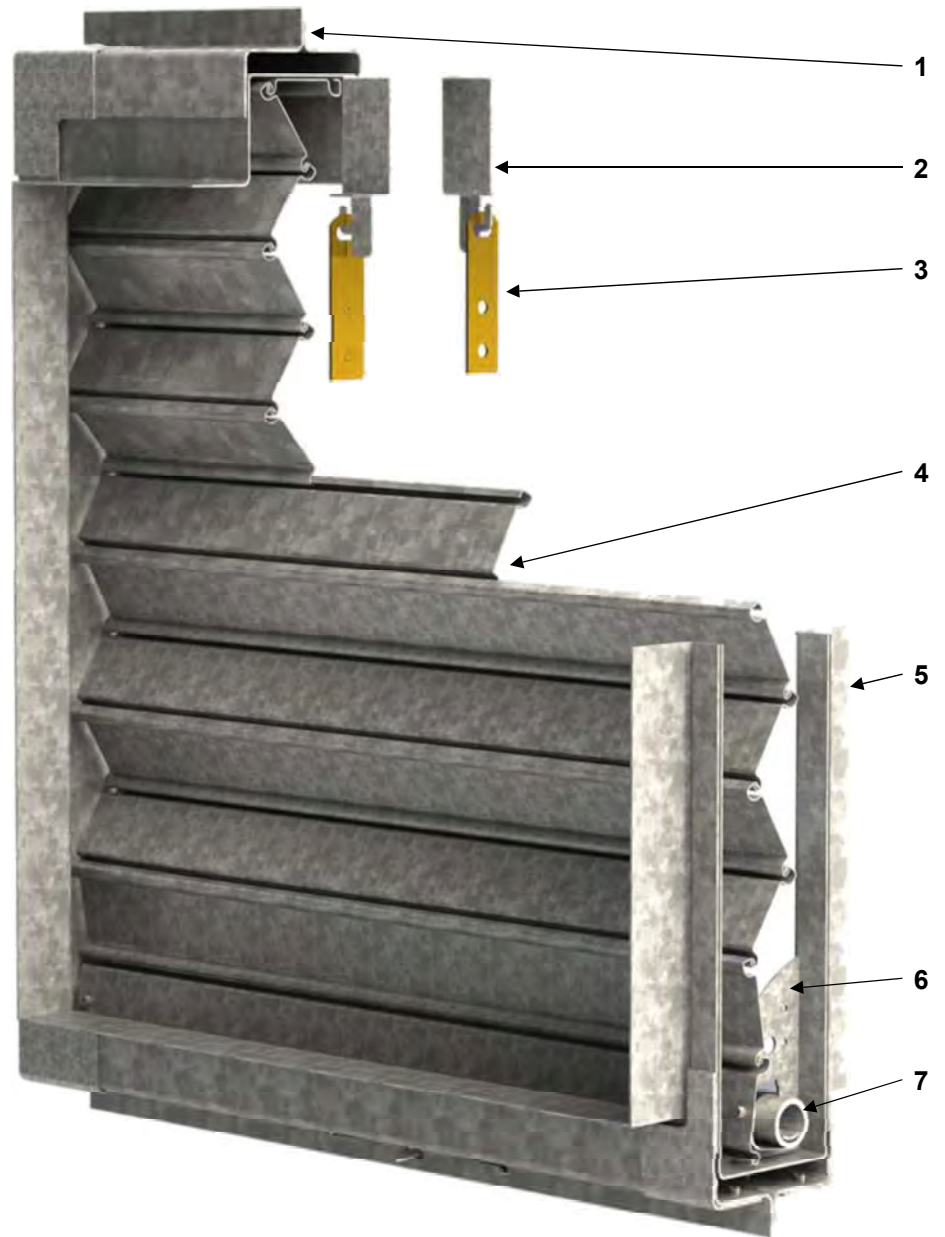

Testing and certification - CE qualifying certification

NCA Series 100 fire damper with HEVAC frame

Tested to:

- **BS EN 1366-2**
Fire resistance test
Vertical installation in masonry wall: Tested for up to 240 minutes
Pass
- **BS EN 13501-3**
Classification of fire resistance performance
Classified to: E 120 (ve i ↔ o)
- **BS ISO 10294-4**
Test of thermal release mechanism
Pass
- **Multiple and stainless steel options**
CE marked against the requirements of EN 15882-2 (EXAP)



NCA Series 100 fire damper with plate frame

Tested to:

- **BS EN 1366-2**
Fire resistance test
Vertical installation in drywall partition: Tested for up to 120 minutes
Horizontal installation in concrete floor slab: Tested for up to 240 minutes
Pass
- **BS EN 13501-3**
Classification of fire resistance performance
Classified to: Vertical, 100mm x 100mm to 1000mm x 1000mm: E 120 (ve i ↔ o)
Vertical, 1000mm x 1000mm to 1250mm x 1000mm: E 90 (ve i → o)
Horizontal: E 120 (ho i → o)
- **BS ISO 10294-4**
Test of thermal release mechanism
Pass
- **Multiple and stainless steel options**
CE marked against the requirements of EN 15882-2 (EXAP)



Testing and certification - Corrosion

Series 100 fire dampers have been tested to:

- **BS EN 60068-2-11:1999**
Salt spray corrosion test
Pass

Testing and certification - Case leakage

Series 100 fire dampers have been tested to:

- **BS EN 1751:1999**
Ventilation for buildings - Air terminal devices
- **DW144**
Specification for sheet metal ductwork

All case types available with Series 100 fire dampers have been tested, and the class/classes to which each has passed are detailed in the table below.

Static pressure differential (Pa)	Quadrilateral spigot S100A** and S100B**		Circular spigot S100C**		Flat oval spigot S100D**	
	DW144	BS EN 1751	DW144	BS EN 1751	DW144	BS EN 1751
100	A & B	A, B & C	A & B	A & B	A & B	A & B
200	A & B	A, B & C	A & B	A & B	A	A
300	A & B	A, B & C	A & B	A & B	A	A
400	A & B	A, B & C	A & B	A & B	A	A
500	A & B	A, B & C	A & B	A & B	A	A
600	B & C	A, B & C	B	A & B	Max leakage exceeded	A
700	B & C	A, B & C	B	A & B	Max leakage exceeded	A
800	B & C	A, B & C	B	A & B	Max leakage exceeded	A
900	B & C	A, B & C	B	A & B	B	A & B
1000	B	A & B	B	A & B	Max leakage exceeded	A
1100	Max leakage exceeded	A, B & C	Max leakage exceeded	A & B	Max leakage exceeded	B
1200	C	A, B & C	Max leakage exceeded	A & B	Max leakage exceeded	B
1300	C	A, B & C	Max leakage exceeded	A & B	Max leakage exceeded	B
1400	C	A, B & C	Max leakage exceeded	A & B	Max leakage exceeded	B
1500	C	A, B & C	Max leakage exceeded	A & B	Max leakage exceeded	B
1600	C	A, B & C	Max leakage exceeded	A & B	Max leakage exceeded	B
1700	C	A, B & C	Max leakage exceeded	A & B	Max leakage exceeded	B
1800	C	A, B & C	Max leakage exceeded	A & B	Max leakage exceeded	B
1900	C	A, B & C	Max leakage exceeded	A & B	Max leakage exceeded	B
2000	C	A, B & C	Max leakage exceeded	A & B	Max leakage exceeded	B

Installation guide

HVC currently have four CE marked installations available for Series 100 fire dampers.

Please see the table below to find the installation type you require.

Installation code	Frame type	Substrate			Orientation		Material		Nominal size range (w x h, mm)	Classification		Page
		Masonry	Drywall partition	Concrete	Vertical	Horizontal	Galvanised steel	Stainless steel		Single section	Multi-section	
FD-1V	HEVAC	✓			✓			✓	100 x 100 to 1250 x 1000	E 120 (ve i↔o)		9
FD-2VP/M	Plate	✓ (M)	✓ (P)		✓				100 x 100 to 1000 x 1000	E 120 (ve i↔o)	E 90 (ve i↔o)	10 and 11
									1000 x 1000 to 1250 x 1000	E 90 (ve i→o)	E 60 (ve i→o)	
									100 x 100 to 1000 x 1000	E 90 (ve i↔o)	E 90 (ve i↔o)	
									1000 x 1000 to 1250 x 1000	E 60 (ve i→o)	E 60 (ve i→o)	
FD-2HC	Plate			✓		✓		100 x 100 to 1000 x 1000	E 120 (ho i→o)	Not available	12	

Please note: HEVAC frames are supplied in galvanised steel only.

Guide to classification

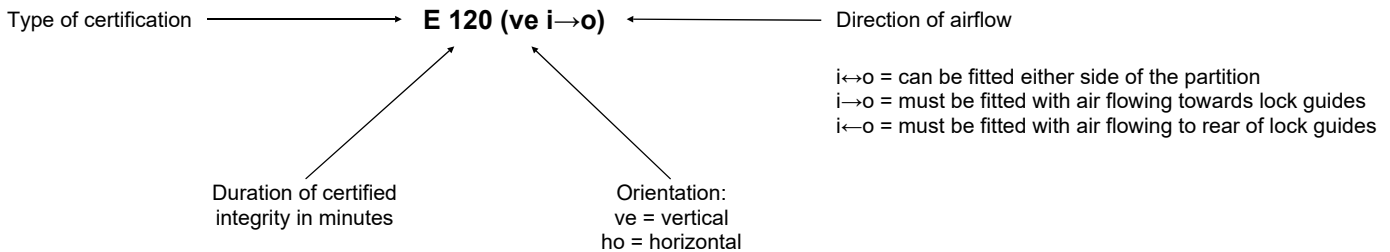



Installation FD-1V

Series 100 fire damper c/w HEVAC frame in masonry wall

HEVAC frames completely surround the damper case. They assist in maintaining the integrity of the damper during a fire.

During a fire, walls may be so severely affected by heat that they begin to deform. Any fire dampers held within the wall could also be subject to this deformation, potentially causing the blade pack to buckle and therefore compromising integrity.

HEVAC frames are designed to allow expansion and deformation of the damper and wall in the event of fire, in turn preventing the damper from being subjected to possibly damaging forces.

Installation involves creating an appropriately sized aperture in the wall, bending the frame tabs out and upwards, and then mortaring the damper into place.

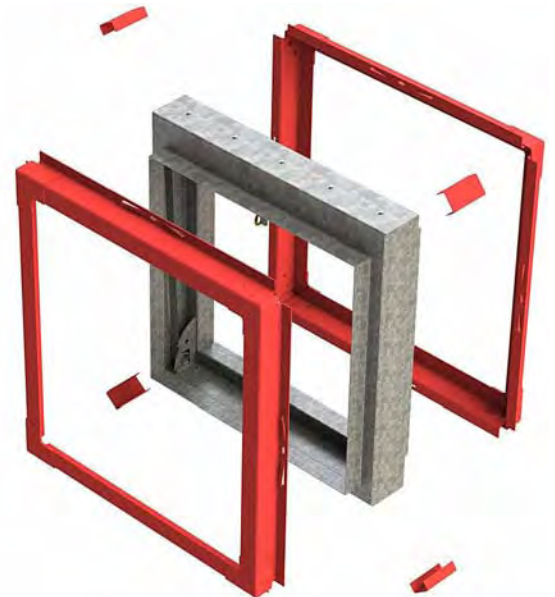

Time and cost saving design

Series 100 fire dampers with HEVAC frames do not need to be tied off to steel anchors set into masonry.

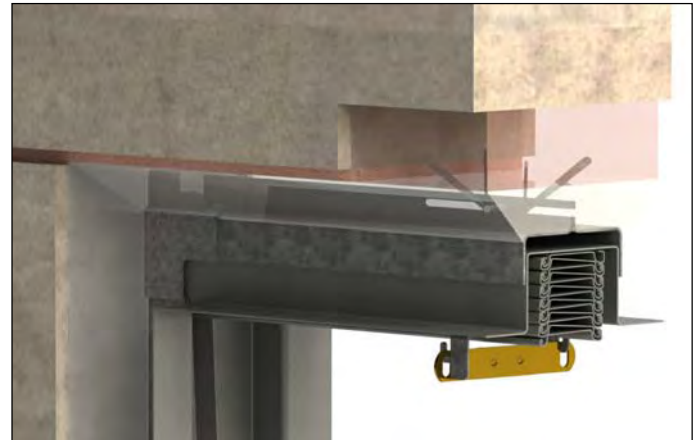
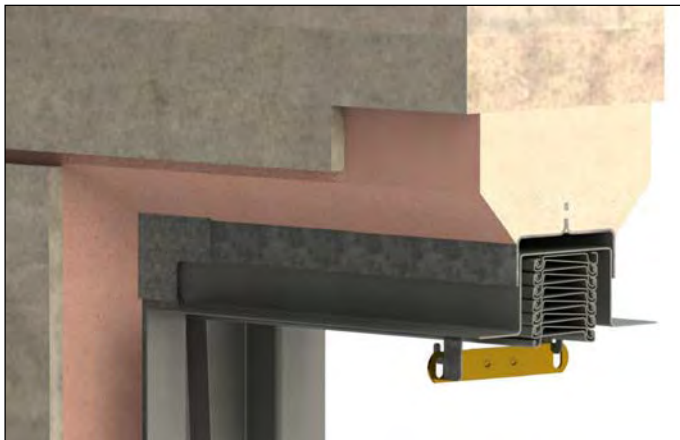

Two copies of the label shown here are supplied with every fire damper fitted with a HEVAC frame.

One label is fitted to the damper before despatch, the other will be supplied loose and must be installed near the damper after installation, for example on ductwork or the wall, so that it remains visible.

 0832
HVC Supplies (Stourbridge) Ltd ***Date of manufacture stamped here*** 0832-CPR-P0015
EN 15650:2010 Fire Damper Series 100 HEVAC
E 120 (ve i→o)
This damper shall be installed as per the manufacturer's instructions. Installation details and DOP available via www.h-v-c.com . Spare product label to be affixed on or near product so it is visible after installation.



Installation FD-2VP

Series 100 fire damper c/w plate frame in drywall partition

Plate frames can be used to integrate fire dampers into drywall partition walls.

Installation involves creating an appropriately sized aperture in the steel framework of a plasterboard wall. The aperture must be lined with a single layer of plasterboard, and the wall cavities filled with mineral wool. Two sheets of plasterboard must be fitted to each side of the wall.

Dampers should be affixed directly to the steelwork with screws at not more than 125mm centres.

Fixing lugs are now available factory fitted to plate frames, please see page 16 for more information.



Time and cost saving design

Series 100 fire dampers with plate frames for drywall partition installations do not require the use of drop rods.

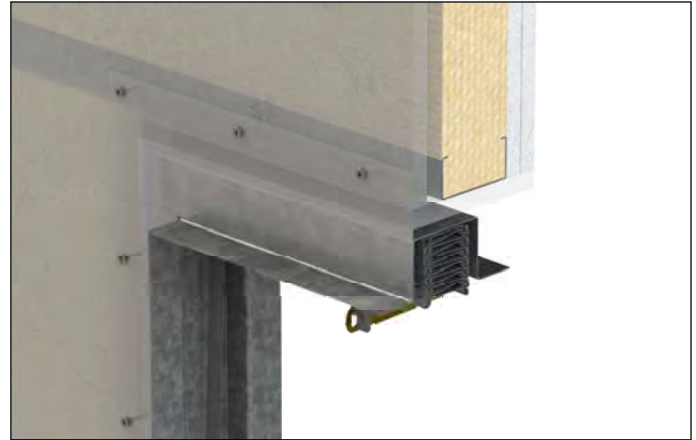
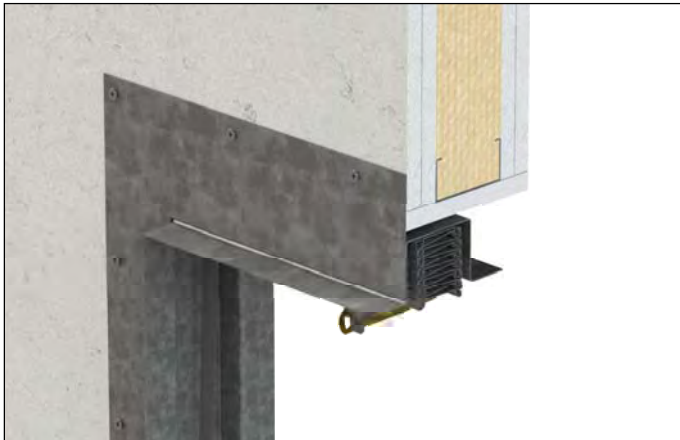

Two copies of the label shown here are supplied with every fire damper fitted with a plate frame.

One label is fitted to the damper before despatch, the other will be supplied loose and must be installed near the damper after installation, for example on ductwork or the wall, so that it remains visible.

 0832
HVC Supplies (Stourbridge) Ltd ***Date of manufacture stamped here*** 0832-CPR-P0015
EN 15650:2010 Fire Damper Series 100 Plate Frame
100mm x 100mm to 1000mm x 1000mm nominal Galvanised single unit: E 120 (ve i→o) Stainless and/or multiple unit: E 90 (ve i→o) Galvanised single unit: E 120 (ho i→o)
1000mm x 1000mm to 1250mm x 1000mm nominal Galvanised single unit: E 90 (ve i→o) Stainless and/or multiple unit: E 60 (ve i→o)
This damper shall be installed as per the manufacturer's instructions. Installation details and DOP available via www.h-v-c.com . Spare product label to be affixed on or near product so it is visible after installation.



Installation FD-2VM

Series 100 fire damper c/w plate frame in masonry wall

Plate frames can be used to integrate fire dampers into masonry walls.

Installation involves simply creating an appropriately sized aperture in the masonry wall and fixing the damper into place.

Dampers should be affixed to the wall with appropriate fixings at not more than 125mm centres.

Fixing lugs are now available factory fitted to plate frames, please see page 16 for more information.



Time and cost saving design

Series 100 fire dampers with plate frames for masonry wall installations do not require the use of drop rods.

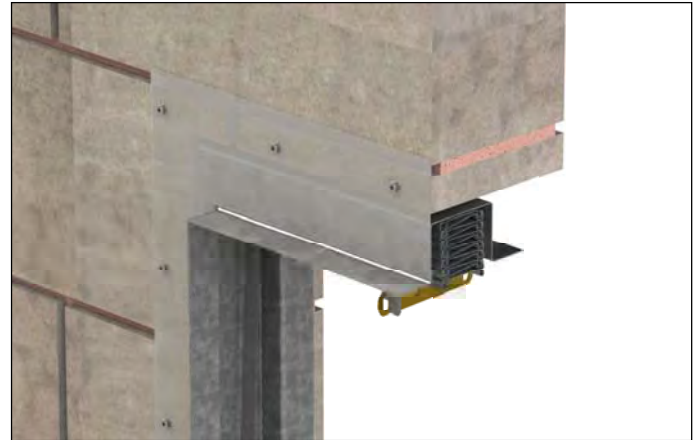

Two copies of the label shown here are supplied with every fire damper fitted with a plate frame.

One label is fitted to the damper before despatch, the other will be supplied loose and must be installed near the damper after installation, for example on ductwork or the wall, so that it remains visible.

To download full installation instructions, declaration of performance and maintenance routine, go to:

www.h-v-c.com/installations

 0832
HVC Supplies (Stourbridge) Ltd ***Date of manufacture stamped here*** 0832-CPR-P0015
EN 15650:2010 Fire Damper Series 100 Plate Frame
100mm x 100mm to 1000mm x 1000mm nominal Galvanised single unit: E 120 (ve i→o) Stainless and/or multiple unit: E 90 (ve i→o) Galvanised single unit: E 120 (ho i→o)
1000mm x 1000mm to 1250mm x 1000mm nominal Galvanised single unit: E 90 (ve i→o) Stainless and/or multiple unit: E 60 (ve i→o)
This damper shall be installed as per the manufacturer's instructions. Installation details and DOP available via www.h-v-c.com . Spare product label to be affixed on or near product so it is visible after installation.



Installation FD-2HC

Series 100 fire damper c/w plate frame in concrete floor

Plate frames can be used to integrate fire dampers into concrete floors.

Installation involves creating an appropriately sized aperture in the concrete slab and then fixing the damper to the floor slab with 'Loden anchor' fixings or equivalent.

Fixings should be 10mm in from the edge of the damper frame, and spaced at a pitch of not more than 125mm.



Time and cost saving design

Series 100 fire dampers with plate frames for concrete floor installations require no backfilling of concrete.

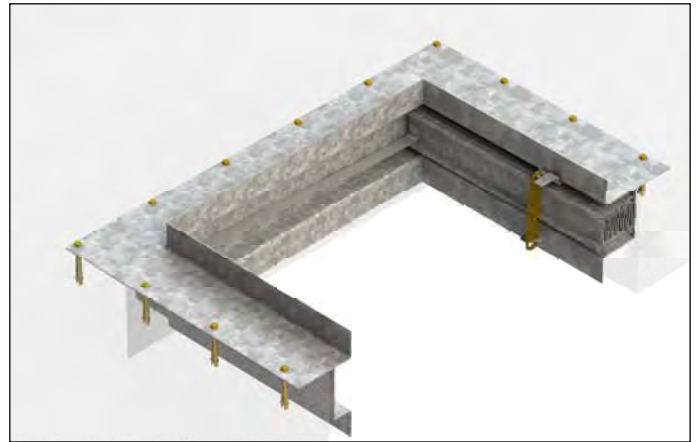
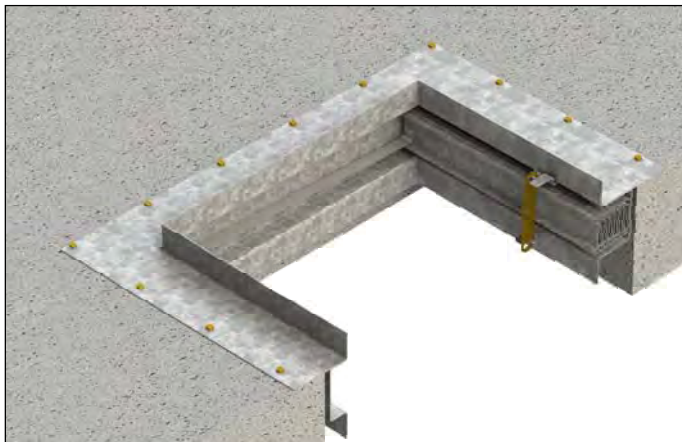

Two copies of the label shown here are supplied with every fire damper fitted with a plate frame.

One label is fitted to the damper before despatch, the other will be supplied loose and must be installed near the damper after installation, for example on ductwork or the wall, so that it remains visible.

 0832
HVC Supplies (Stourbridge) Ltd ***Date of manufacture stamped here*** 0832-CPR-P0015
EN 15650:2010 Fire Damper Series 100 Plate Frame
100mm x 100mm to 1000mm x 1000mm nominal Galvanised single unit: E 120 (ve i→o) Stainless and/or multiple unit: E 90 (ve i→o) Galvanised single unit: E 120 (ho i→o)
1000mm x 1000mm to 1250mm x 1000mm nominal Galvanised single unit: E 90 (ve i→o) Stainless and/or multiple unit: E 60 (ve i→o)
This damper shall be installed as per the manufacturer's instructions. Installation details and DOP available via www.h-v-c.com . Spare product label to be affixed on or near product so it is visible after installation.

Guide: Why is it so important to use certified fire dampers?

On the 1st of July 2013 it became EU law that any fire dampers sold into the UK and EU markets must be CE marked.

In the event of a severe fire, fire dampers may make the difference between partial damage to a building or total loss, or even the difference between life and death for both the occupants of the building, and for the fire crews who may be sent in to extinguish the fire.

The test fire dampers must pass to become certified is BS EN 1366-2. This looks to replicate an absolute worst case scenario of there being a severe fire whilst ductwork remains pressurised.

Fire dampers are bolted to a gas furnace, which during the test exposes them to temperatures approaching 1200°C with a pressure differential of 300 Pa on either side of the blade pack.

Leakage through the damper must remain below 360 m³/hr/m² at all times or the damper fails.

Testing to this extreme standard ensures that only the very best fire dampers can ever become CE marked.

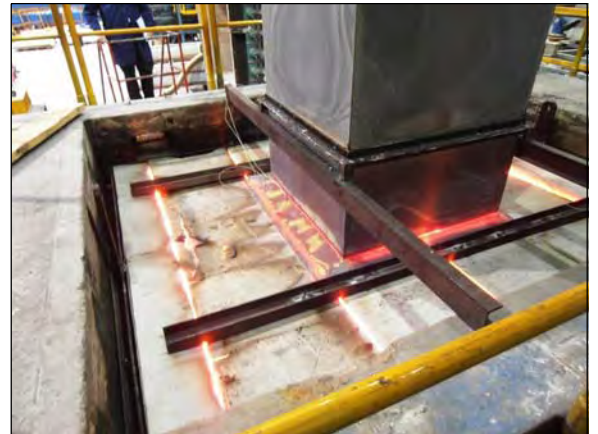

Series 100 fire damper during a horizontal fire test
The test was stopped after 4 hours and 24 minutes because the 150mm thick concrete slabs themselves were failing. Damper leakage was actually decreasing at this stage.



Damper blades glowing during a vertical fire test
Fire dampers are exposed to temperatures approaching 1200 degrees celsius during fire testing, causing the galvanised steel blade pack to glow red hot.



Remains of a drywall partition after a fire test
The two 15mm thick layers of plasterboard have been completely destroyed by the ferocity of the fire and the fire damper blade pack itself has been completely deformed.

Technical drawings - HEVAC frame

S100A*H

- Square spigot
- Blades in airstream
- Spigot 6mm under nominal (duct) width and height
- Recommended for sizes under 200mm high
- Min size: 100mm W x 100mm H
- Max size: 1250mm W x 1000mm H

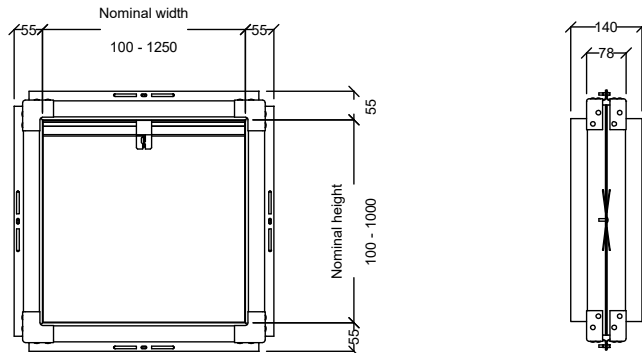

S100B*H

- Square spigot
- Blades out of airstream
- Spigot 6mm under nominal (duct) width and height
- Recommended for sizes equal to or over 200mm high
- Min size: 100mm W x 200mm H
- Max size: 1250mm W x 1000mm H

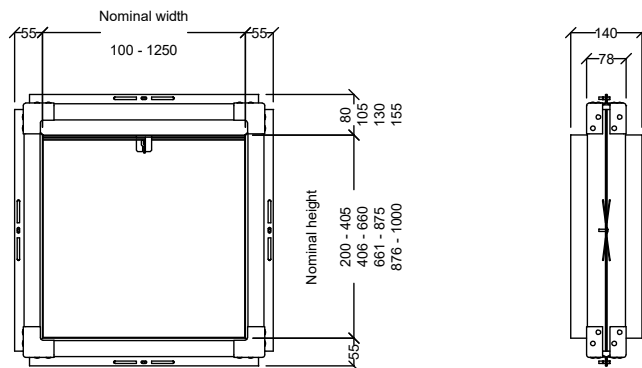

S100C*H

- Circular spigot
- Blades out of airstream
- Spigot 3mm under nominal (duct) diameter
- Min size: 100mm dia
- Max size: 1000mm dia

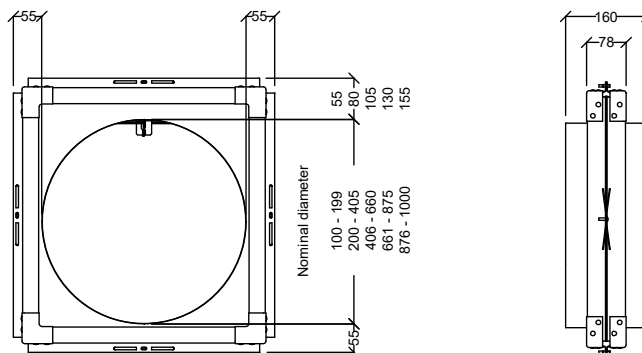

S100D*H

- Flat oval spigot
- Blades out of airstream
- Spigot 3mm under nominal (duct) width and height
- Min size: 150mm W x 100mm H
- Max size: 1250mm W x 1000mm H

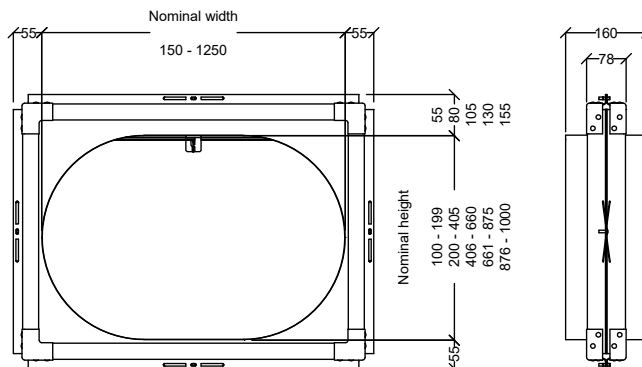

Please note:

Units above the maximum size can be made in multiple sections. Please contact us for more information.

Technical drawings - Plate frame

S100A*P

- Square spigot
- Blades in airstream
- Spigot 6mm under nominal (duct) width and height
- Recommended for sizes under 200mm high
- Min size: 100mm W x 100mm H
- Max size: 1250mm W x 1000mm H
(refer to page 8 for more information)

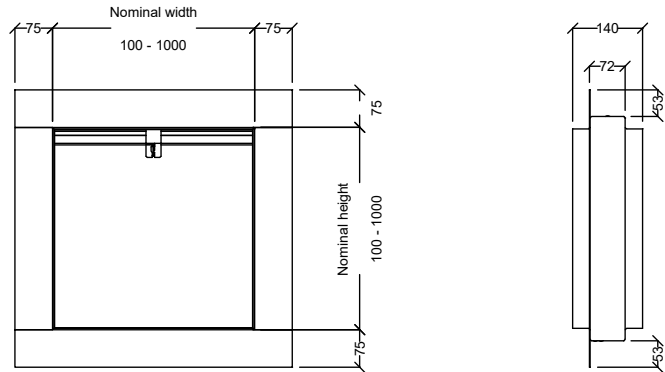

S100B*P

- Square spigot
- Blades out of airstream
- Spigot 6mm under nominal (duct) width and height
- Recommended for sizes equal to or over 200mm high
- Min size: 100mm W x 200mm H
- Max size: 1250mm W x 1000mm H
(refer to page 8 for more information)

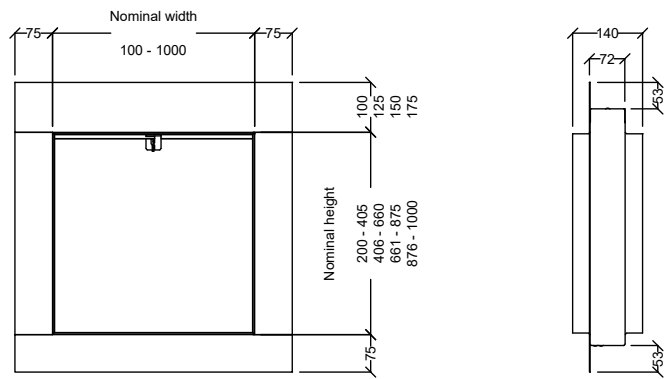

S100C*P

- Circular spigot
- Blades out of airstream
- Spigot 3mm under nominal (duct) diameter
- Min size: 100mm dia
- Max size: 1000mm dia

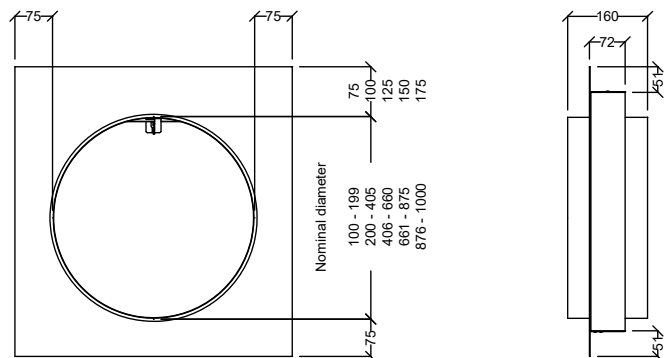

S100D*P

- Flat oval spigot
- Blades out of airstream
- Spigot 3mm under nominal (duct) width and height
- Min size: 150mm W x 100mm H
- Max size: 1250mm W x 1000mm H
(refer to page 8 for more information)

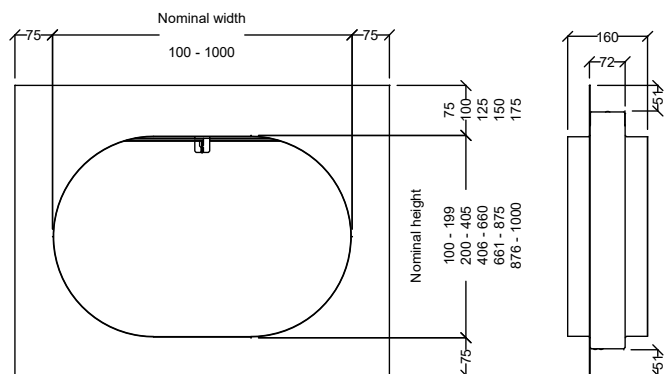

Please note:

Units above the maximum size can be made in multiple sections. Please contact us for more information.

Installation accessories

Fixing lugs

Now available factory fitted to fire dampers equipped with plate frames, fixing lugs allow dampers to be hung from drop rods in addition to the approved vertical plate frame installation methods detailed on pages 10 and 11.

Factory drilled with an 11mm diameter hole to suit up to an M10 drop rod, fixing lugs aid installation by supporting the damper during fitment.

Nuts and washers should only be positioned below the fixing lugs, allowing the damper/drop rod to expand in the event of fire.

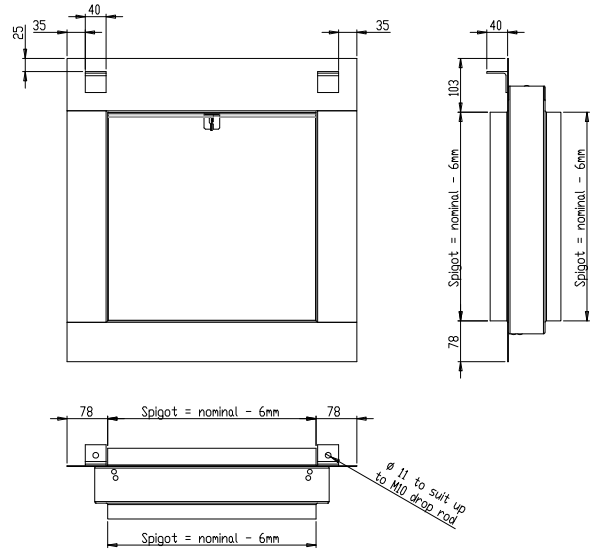

Damper operation methods

Fusible links (standard operation method)

The standard operation method, fusible links are a two part brass unit, joined with a solder formulated to melt at a specific temperature.

Series 100 fusible links incorporate two dimples which act to prevent creep over time. This ensures that the damper only releases when the solder has melted, rather than through fatigue due to the constant pressure exerted by the blade pack.

Available ratings:

72°C (Standard)
96°C
145°C
183°C

Electromagnets

Power normally on, damper closes upon loss.

Available for systems which require dampers to close upon loss of power.

The fusible link is retained so the damper will still close upon reaching the specified temperature.

Please note that unless back up power supplies are in place, a power cut will result in dampers closing.

Not available on square/rectangular/flat oval dampers with a nominal height of less than 200mm, or on circular dampers with a nominal diameter of less than 250mm.

Available models:

24V DC
24V AC (with rectifier)
230V DC
230V AC (with rectifier)

Maintenance assisting options

Resettable link / Easy maintenance link

Resettable links make damper testing and maintenance easier by reducing the complexity of releasing and resetting a damper. Normally the link must be manually removed from the bracket which can be awkward, especially through small duct access doors.

Resettable links incorporate a spring loaded lever arm which holds one end of the fusible link. To release the damper during testing depress the lever arm to release the blade pack.

Resetting the pack then involves pushing the blades back into the header, and putting the link back into position.

Pull ring

Attached to the bottom blade, when working from upstream of the damper pull rings allow the blade pack to be pulled off the lock guides and reset into the damper header.

Damper status indicators

Visual position indicator

VPIs allow damper blade position to be observed from outside the duct.

Positioned on the bottom of the damper frame, VPIs consist of a clear plastic tube with a red insert.

When the damper is open, the red insert is fully recessed. When closed, the insert is extended.



Microswitch

Made by Honeywell specifically for HVC, this double pole, single throw microswitch completes a circuit when the blade pack falls, remotely indicating blade position.

A spring arm protrudes from the microswitch into the blade path. Upon blade closure, the arm is pushed down. The arm is spring-loaded so no resetting to the switch itself is required.

The microswitch body allows connection on the back or either side to assist fitting.

Not available on square/rectangular/flat oval dampers with a nominal height of less than 100mm, or on circular dampers with a nominal diameter of less than 200mm.

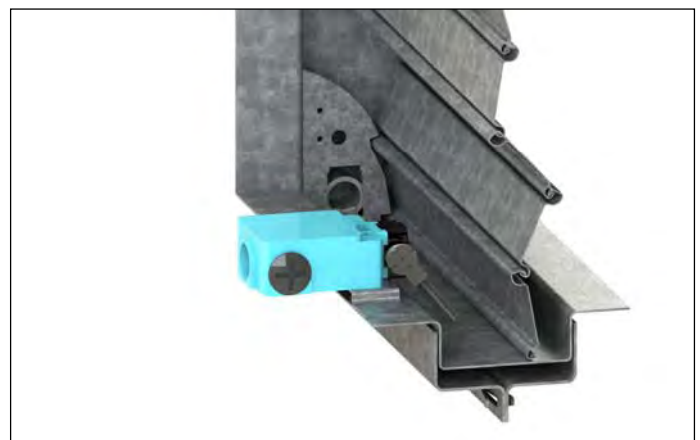

Installation

Installation should take into account the requirements of future maintenance, with a view to providing adequate access to fire dampers for testing and cleaning purposes.

We are able to supply a full range of access doors to facilitate access into ductwork.

Important note:

Installation into chlorinated environments

We are unable to supply S100 fire dampers suitable for installation into chlorinated environments, swimming baths for example.

Any dampers installed into environments where chlorine is present shall be considered to be installed in an unsuitable location and will therefore not be covered by our standard 12 month warranty.

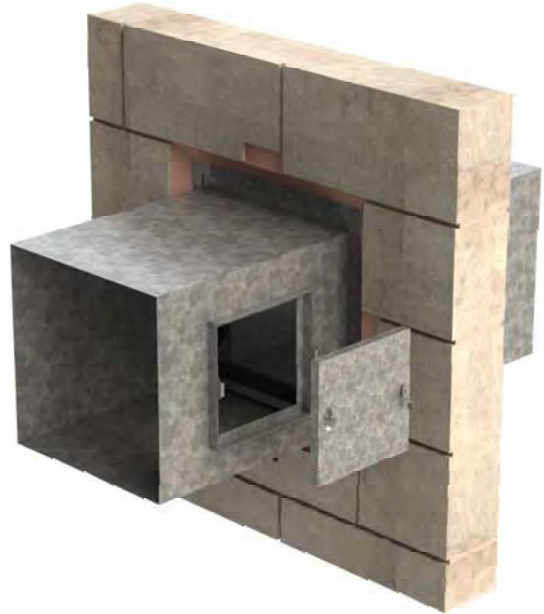

Maintenance

Maintenance of fire dampers is essential to ensure they remain in good working condition for the life of the building.

Testing and maintenance must be carried out in accordance with:

BS 9999

Code of practice for fire safety in the design, management and use of buildings.