

# SmartFil

Art. No.: 64 650 104



## Technical Data

Filter	
Filter stages	2
Filter method	Storage Filter
Filter surface	25 m <sup>2</sup>
Type of filter	Safe Change Filter
Filter material	Non-woven polyester
Filter efficiency	> 99.5 %
Filter class	E12
Additional filters	Pre-filter (aluminium)
Basic data	
Extraction capacity	1100 m <sup>3</sup> /h
Weight	131 kg
Motor power	1.5 kW
Power supply	3 x 400 V / 50 Hz
Rated current	3.1 A
Control voltage	24 V, DC
Noise level	70 dB(A)
Additional information	
IFA-Certification	W3-Approved
Fan type	Radial fan
Exhaust arm type	rigid metal tube arm
Length of exhaust arm	3 m

## Applications

- Suitable for all materials, including high-alloy steel
- Medium levels of smoke and dust
- Frequent use
- Alternating work places

## Benefits

- Exhaust arm requires less adjustment due to flow-optimised exhaust hood design
- Increased safety due to filter monitoring
- Increased safety with safe filter change
- Very economic due to long lasting high capacity filters

## Properties

- 360 degrees rotating exhaust hood with damper
- 25m<sup>2</sup> filter surface
- Compact and solid design
- W3/IFA certified
- Exhaust arm 3 m

## Accessories

- Automatic start-stop
- Workplace lighting incl. on/off switch at the hood



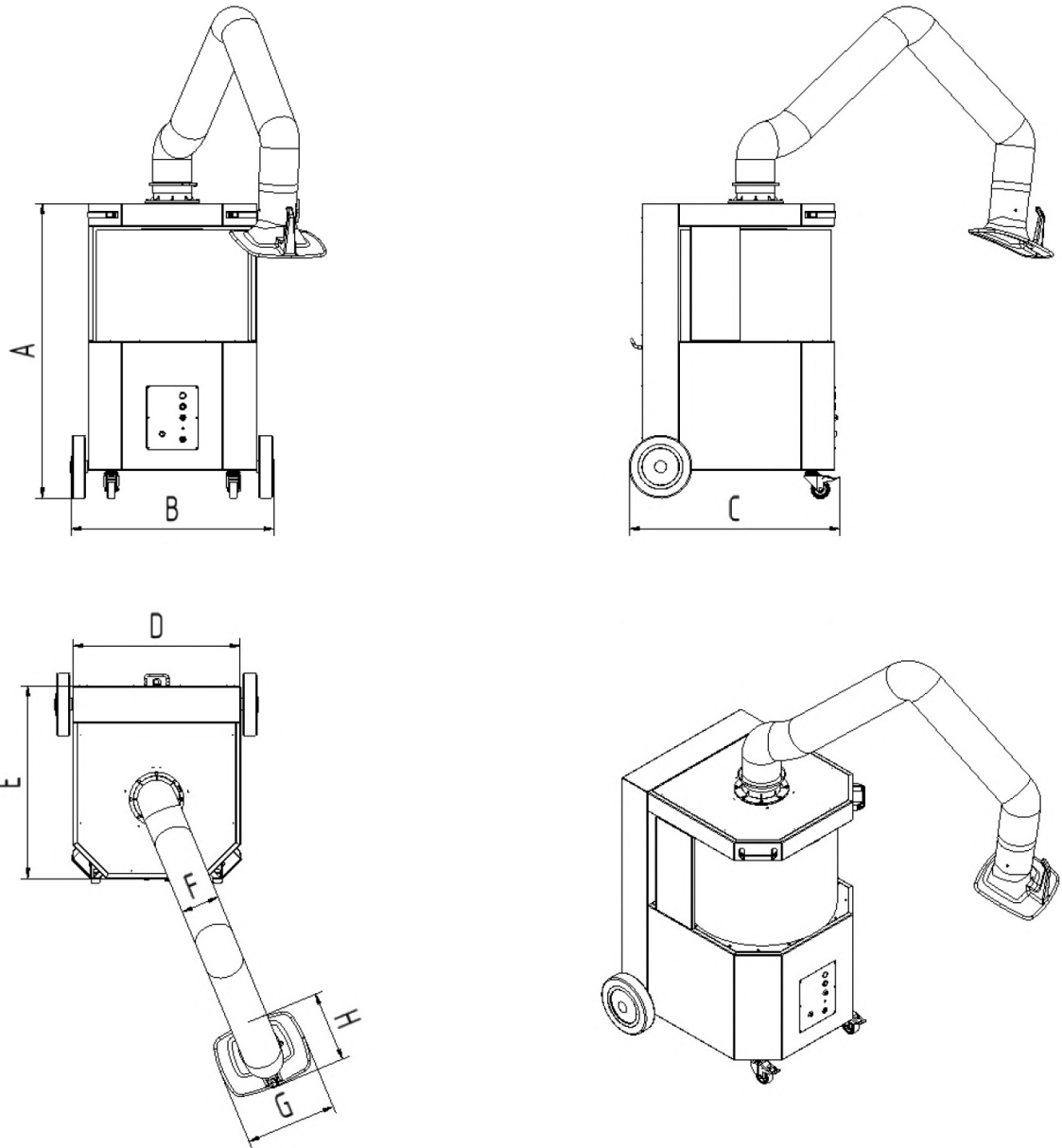

## Technical Data

### Dimensions

A	1169 mm
B	795 mm
C	836 mm
D	667 mm
E	764 mm
F	150 mm
G	360 mm
H	295 mm