

WallMaster

Art. No.: 65 750



Technical Data

Filter

Filter stages	2
Filter method	Storage Filter
Filter surface	42 m ²
Type of filter	Safe Change Filter
Filter material	Non-woven polyester
Filter efficiency	> 99.5 %
Filter class	E12

Basic data

Dimensions (w x t x h)	765 x 715 x 795 mm
Weight	65 kg
Suitable for air volumes of up to	1600 m ³ /h

Applications

- Medium levels of smoke and dust
- Modular extension in combination with capturing elements
- One or two workplaces

Benefits

- Increased safety with safe filter change
- Very economic due to long lasting high capacity filters
- Inexpensive welding smoke filter for retrofitting of existing capturing elements
- Robust filter monitoring by means of pressure gauge

Properties

- Retrofittable
- Integrated lifting device for filter change
- Easy and quick installation
- Compact and solid design
- Mechanical operation of the filter unit



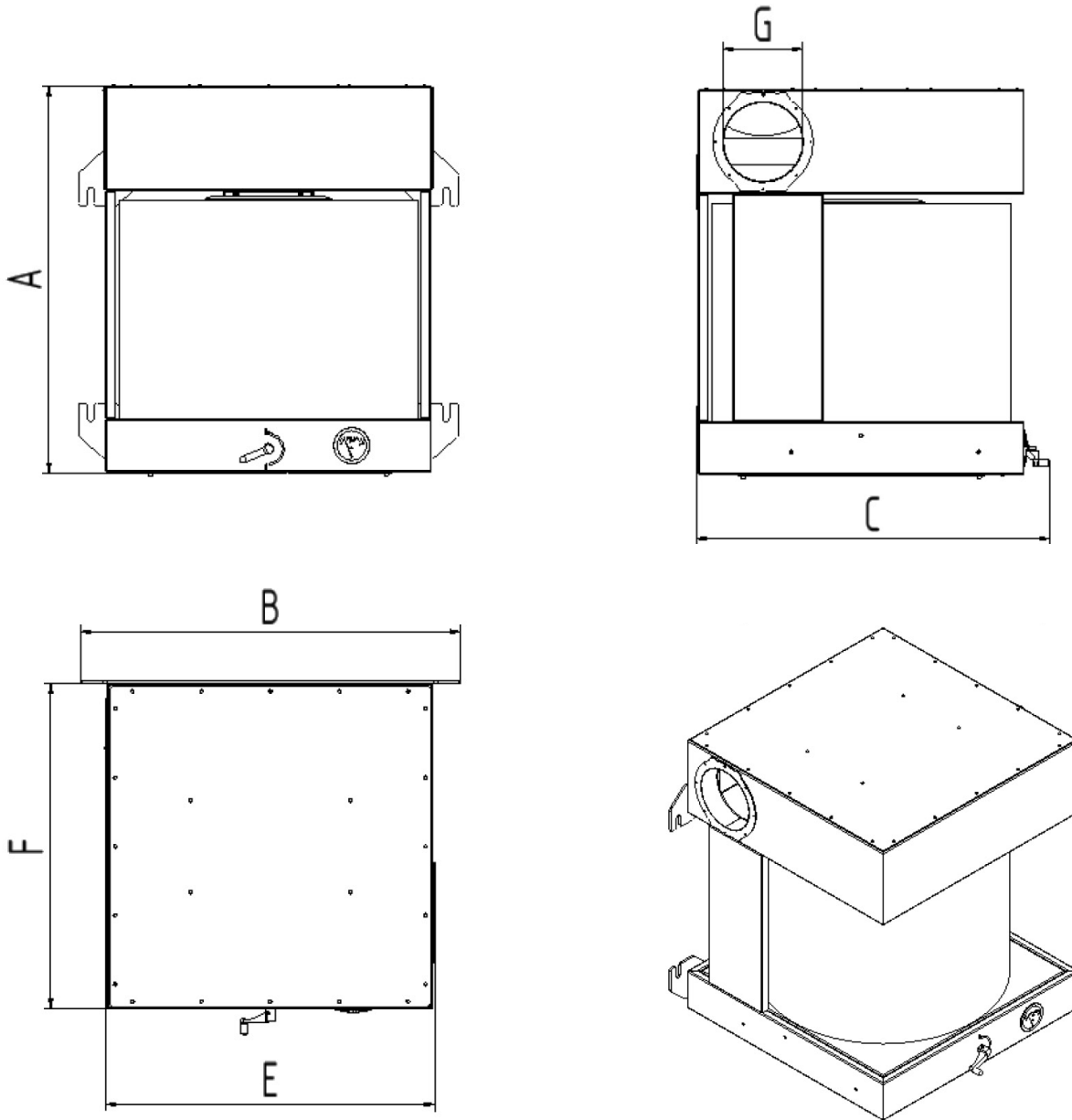

Technical Data

Dimensions

A	795 mm
B	765 mm
C	715 mm
E	660 mm
F	660 mm
G	160 mm