

TD-SILENT - MODELS 160 TO 1000



Low profile "Mixed-flow" fans with sound-absorbent insulation. Extremely quiet. Certified of Approval Noise Abatement Society (TD-350, TD-500, TD-800 and TD-1000 models).

Manufactured in plastic material, with a specifically designed internal skin to direct the sound waves at the right angle for them to be captured by the sound-absorbent material (1). Fitted with rubber gaskets on the inlet and outlet to absorb vibrations, a body that can be dismantled. Connection box can be rotated 360°, to facilitate easy connection of the power cable.

Motors

Speed controllable 230V-50Hz motor, of two speed or 3-speed motors (depending on the models). IP44.

Motors are class B, with ball bearings and safety thermal overload protection.

(1) Except the TD-160 SILENT, that is fitted with the special floating motor system patented by S&P.

Additional information

The models offer solutions to ventilation problems, especially in places where people work and low sound level is required.



Validated mark of approval
noise abatement society
[Models 350,
500, 800 and 1000]

TD-SILENT-T models

TD-SILENT versions fitted with a run-on-timer adjustable within 1 and 30 minutes and onespeed or 3-speed motors (depending on the model) not suitable for speed control.

TD-SILENT - MODELS 1300 AND 2000



Low profile "Mixed-flow" fans with soundabsorbent insulation. Extremely quiet. Certified of Approval Noise Abatement Society (TD-2000 model). Constructed from sheet steel with epoxy polyester paint, acoustic insulation (MO) glass fibre, within outer shell.

Aerodynamic inlet to improve airflow and reduce sound. Detachable fan unit without demounting duct connections. IP44. External terminal box IP55. Removeable fan body with 3 speed motor, single phase 230V-50/60Hz speed controllable, Class F, external rotor aluminium motor with capacitor and thermal protection.

Additional information

The models offer solutions to ventilation problems, especially in places where people work and low sound level is required.



Validated mark of approval
noise abatement society
[Model 2000]

IN-LINE MIXED FLOW DUCT FANS ULTRA-QUIET TD-SILENT Series



MODELS 250 TO 1000



Low profile

The low profile of the TD-SILENT fans makes them the most effective solution for installations where space is very limited, especially in ceiling voids.

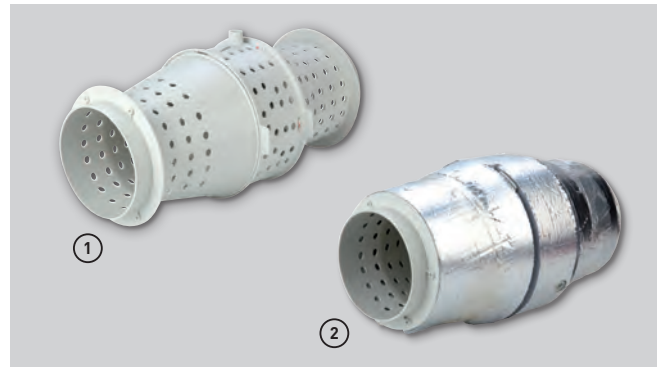

Low noise level

Sound waves produced inside the TD, are directed through the perforated inner skin (1) and absorbed by the layer of sound absorbent material (2).



Easymaintenance

Removable motor-body assembly to easy cleaning and repairing without touching the ducts. Support plastic brackets simplify the operation.

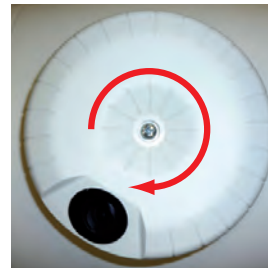

Connection box rotated 360°

Connection box can be rotated 360°, to facilitate easy connection of the power cable.



Rubber seals

Bi-material inlet and outlet incorporating a rubber seal to facilitate installation and absorb vibrations.



MODELS WITH RUN-ON-TIMER

Models TD-SILENT-T (from models 250 to 1000) are fitted with an adjustable timer between 1 and 30 minutes and are supplied with a one-speed or 3-speed motors (depending on the model) not suitable for speed control.



Support bracket

Support bracket for installing on a wall or ceiling, incorporating twin-material support brackets for the motor section that absorbs vibration.

Easy to mount



Loosen and open clamps on both sides.

Remove the fan body.

Remove the terminal box lid.

Connect electrical supply.

Remount the fan body by tightening the clamps.

MODEL 160



SILENT-ELASTIC-BLOCKS
 Model TD-160/100N SILENT offer very low noise level, with a **motor mounted on silentelastic-blocks** which absorb the vibrations.



MODELS 1300 AND 2000



Low profile - compact

Low profile fans TD-1300/250 SILENT and TD-2000/315 SILENT are ideal for installations where space is very limited, especially in ceiling voids.



Easy maintenance

Detachable fan unit for maintenance, or cleaning, without demounting duct connections.

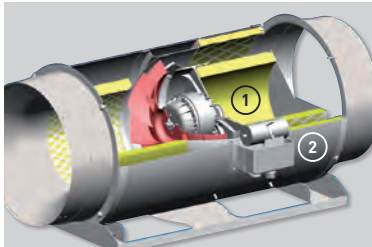

Low noise level

- ① Acoustic insulation (A2-s1, d0) glass fibre.
- ② Outer shell.
- ③ Aerodynamic inlet to improve air flow and reduce sound.
- ④ Attenuating perforated skin.



Support bracket

Suitable for wall or ceiling mounting. Fixing brackets to the motor-body included.



IP55 REMOTE terminal box

Easy installation and connection.

IN-LINE MIXED FLOW DUCT FANS ULTRA-QUIET

TD-SILENT Series



TECHNICAL CHARACTERISTICS

TD-SILENT	Speed (r.p.m.)	Maximum absorbed power (W)	Maximum absorbed current (A)	Maximum airflow (m³/h)	Sound pressure level* (dB(A))	Min-Max air temperature (°C)	Weight (kg)	Duct diameter (mm)	3-speed switch	Speed controller	Wiring diagram** (n°)
TD-160/100 N SILENT	2400	29	0,17	180	24	-20/+40	1,4	100	COM-2 REGUL-2	RMB-1,5 REB-1	9, 10
	2200	18	0,11	150	22						
TD-250/100 SILENT	2210	27	0,12	250	25	-20/+40	5,4	100	COM-2 REGUL-2	RMB-1,5 REB-1	9, 10
	1680	21	0,1	200	20						
TD-350/125 SILENT	2100	27	0,12	330	23	-20/+40	5	125	COM-2 REGUL-2	RMB-1,5 REB-1	9, 10
	1650	21	0,1	260	18						
TD-500/150-160 SILENT 3V	2480	59	0,26	550	27	-20/+60	6	150/160	COM-3 INTER 4P	RMB-1,5 REB-1	9, 10
	2060	50	0,22	450	22						
	1610	45	0,2	350	17						
TD-800/200 SILENT 3V	2170	102	0,5	910	28	-20/+60	8,7	200	COM-3 INTER 4P	RMB-1,5 REB-1	9, 10
	1870	92	0,47	780	24						
	1660	90	0,46	690	22						
TD-1000/200 SILENT 3V	2450	130	0,55	1.040	29	-20/+60	8,7	200	COM-3 INTER 4P	RMB-1,5 REB-1	9, 10
	2210	127	0,55	910	27						
	1920	122	0,53	790	24						
TD-1300/250 SILENT 3V	2530	204	0,85	1.320	36	-20/+60	20	250	COM-3 INTER 4P	RMB-1,5 REB-1	12, 13
	2230	163	0,68	1.160	33						
	2030	144	0,6	1.040	31						
TD-2000/315 SILENT 3V	2670	293	1,25	1.770	39	-40/+60	25	315	COM-3 INTER 4P	RMB-1,5 REB-2,5	12, 13
	2490	232	0,97	1.610	38						
	2240	190	0,78	1.480	36						

* Sound pressure level radiated at 3 m at free air conditions with rigid ducts at the inlet and at the outlet.

** See section of Wiring Diagrams.

TD-SILENT	Speed (r.p.m.)	Maximum absorbed power (W)	Maximum absorbed current (A)	Maximum airflow (m³/h)	Sound pressure level* (dB(A))	Min-Max air temperature (°C)	Weight (kg)	Duct diameter (mm)
TD-160/100 NT SILENT	2400	29	0,17	180	24	-20/+40	1,4	100
TD-250/100 SILENT T	2140	28	0,12	250	34	-20/+40	2	100
TD-350/125 SILENT T	2050	26	0,11	330	33	-20/+40	2	125
TD-500/150-160 SILENT T 3V**	2590	53	0,21	560	35	-20/+60	2,7	150
	2150	44	0,19	470	31			
	1820	41	0,18	390	26			
TD-800/200 SILENT T 3V**	2170	102	0,5	910	28	-20/+60	8,7	200
	1870	92	0,47	780	24			
	1660	90	0,46	690	22			
TD-1000/200 SILENT T 3V**	2450	130	0,55	1.040	29	-20/+60	8,7	200
	2210	127	0,55	910	27			
	1920	122	0,53	790	24			

* Radiated sound pressure level measured at 3 m, in free field conditions, with rigid ducts at the inlet and outlet.

** Temperisation only on high speed

DIMENSIONS (mm)

TD-160/100 N SILENT

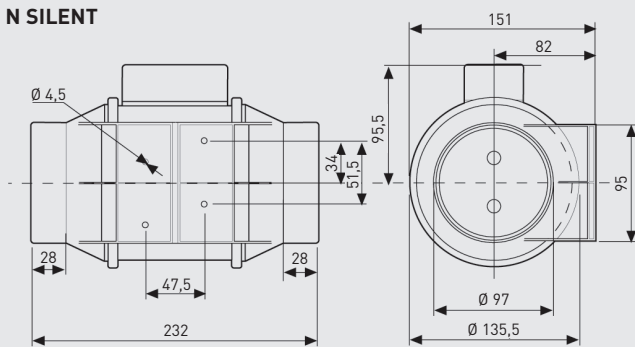

TD-SILENT 250 to 1000

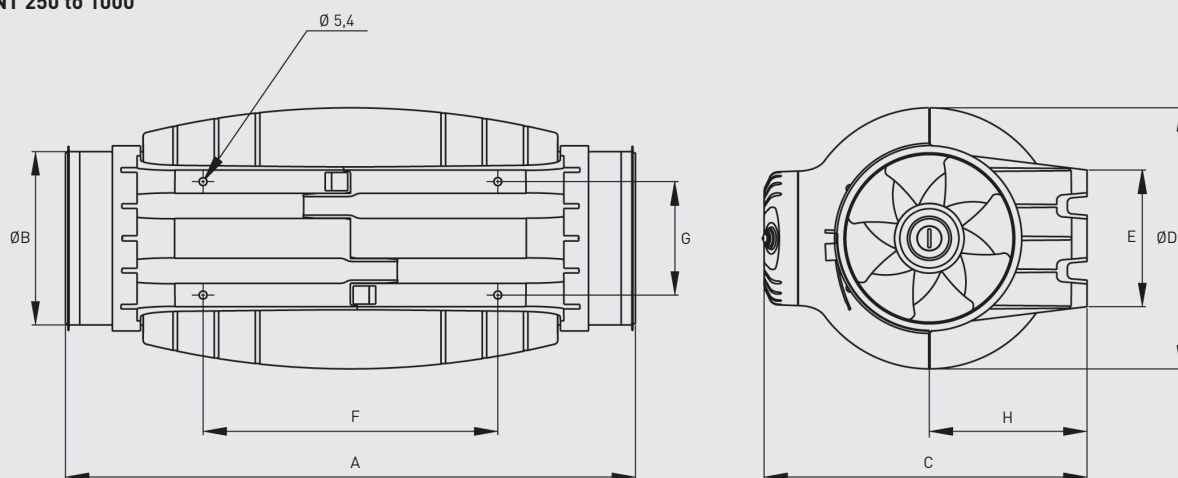

	A	ØB	C	ØD	E	F	G	H
TD-250/100	575	97	252	204	100	250	83	121
TD-350/125	462	123	252	204	100	250	83	121
TD-500/150-160*	484	147	274	221	116	250	96	134
TD-800/200	568	198	327	264	145	340	129	164
TD-1000/200	568	198	327	264	145	340	129	164

* It provides an additional rubber gasket for installation in 160 mm ducts.

TD-SILENT 1300 and 2000

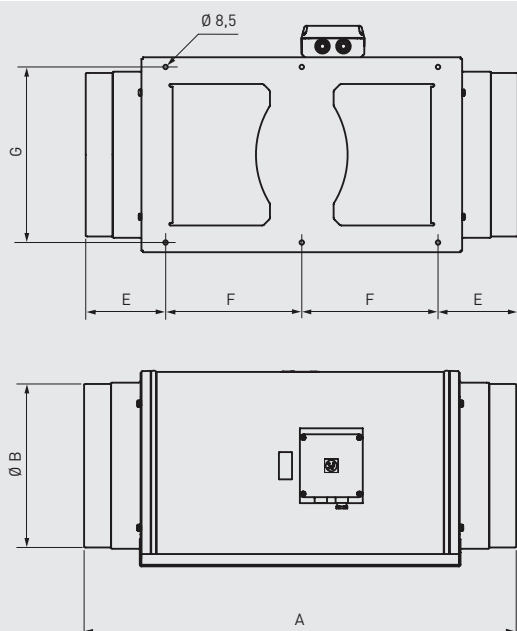

	A	B	C	D	E	F	G	H
TD-1300/250 SILENT	680	248	331	387	140	200	280	171
TD-2000/315 SILENT	825	312	373	432	152	260	335	192

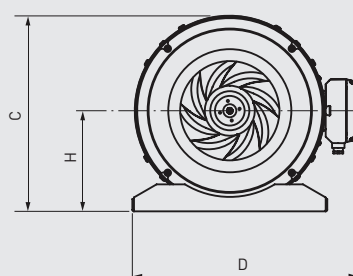

PERFORMANCE CURVES

- q_v : Airflow in m^3/h .
- p_{sf} : Static pressure in Pa.
- Dry air at 20°C and 760 mmHg.
- Performance data in accordance with ISO 5801 and AMCA 210-99 Standards.
- SFP: Specific fan power in $W/m^3/s$ (blue curves).

HS : High speed
MS: Medium speed
LS: Low speed

TD-160/100N SILENT

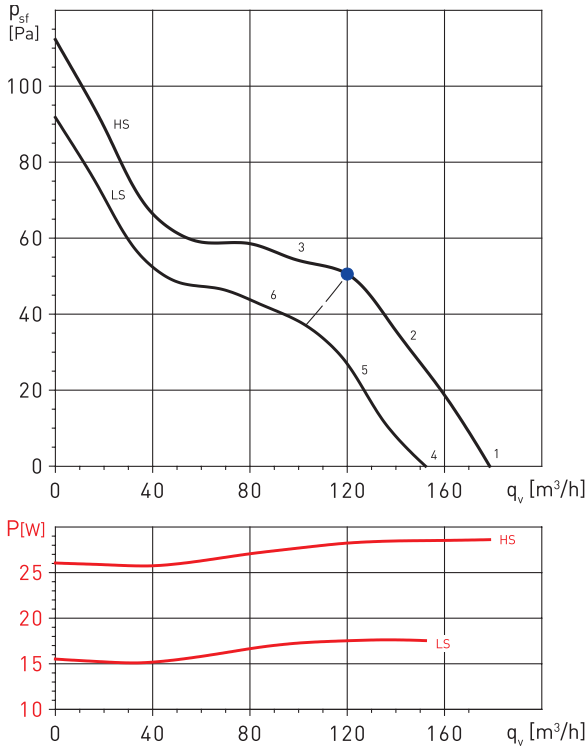

TD-250/100 SILENT

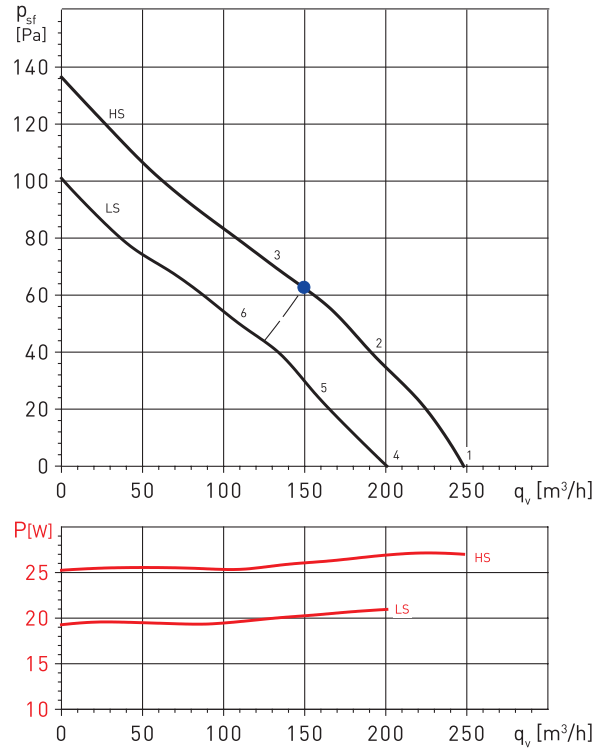

Sound power level spectrums in dB(A)

Working point		63	125	250	500	1.000	2.000	4.000	8.000	LwA
1	Inlet	22	34	41	47	53	49	40	31	56
	Outlet	22	43	38	50	51	47	41	32	55
	Break-out	21	27	41	35	36	40	33	22	45
2	Inlet	21	36	39	47	52	48	39	30	55
	Outlet	22	42	37	50	50	46	41	31	54
	Break-out	20	29	39	35	35	39	32	21	44
3	Inlet	24	37	41	48	52	47	39	30	55
	Outlet	27	42	38	50	51	45	40	31	55
	Break-out	23	30	41	36	35	38	32	21	45
4	Inlet	22	31	37	45	51	46	38	29	53
	Outlet	22	38	34	48	49	45	39	29	53
	Break-out	19	27	36	33	35	38	31	21	42
5	Inlet	21	33	37	45	50	46	37	28	53
	Outlet	22	38	35	48	48	44	38	29	52
	Break-out	18	29	36	33	34	38	30	20	42
6	Inlet	23	34	39	45	50	45	37	28	53
	Outlet	26	38	36	48	49	44	38	28	53
	Break-out	20	30	38	33	34	37	30	20	43

Sound power level spectrums in dB(A)

Working point		63	125	250	500	1.000	2.000	4.000	8.000	LwA
1	Inlet	23	30	46	53	52	44	38	30	57
	Outlet	26	32	45	54	47	41	36	29	55
	Break-out	22	27	41	42	36	31	25	18	46
2	Inlet	24	32	46	52	52	45	38	30	56
	Outlet	24	33	44	52	46	41	37	29	54
	Break-out	23	29	41	41	36	31	25	18	45
3	Inlet	25	33	42	51	55	47	41	34	57
	Outlet	25	35	40	51	49	42	39	32	54
	Break-out	23	30	37	40	39	34	27	22	44
4	Inlet	23	33	42	47	48	38	31	25	51
	Outlet	23	33	40	47	42	34	29	24	49
	Break-out	20	30	36	35	32	24	18	15	40
5	Inlet	25	33	43	46	51	40	33	26	53
	Outlet	23	34	42	47	44	36	32	26	50
	Break-out	22	31	37	35	34	26	19	16	41
6	Inlet	24	31	39	48	51	43	36	28	54
	Outlet	25	33	38	49	45	38	34	27	51
	Break-out	22	28	32	37	35	29	22	19	41

PERFORMANCE CURVES

- q_v : Airflow in m^3/h .
- p_{sf} : Static pressure in Pa.
- Dry air at 20°C and 760 mmHg.
- Performance data in accordance with ISO 5801 and AMCA 210-99 Standards.
- SFP: Specific fan power in $W/m^3/s$ (blue curves).

HS : High speed
MS: Medium speed
LS: Low speed

TD-350/125 SILENT

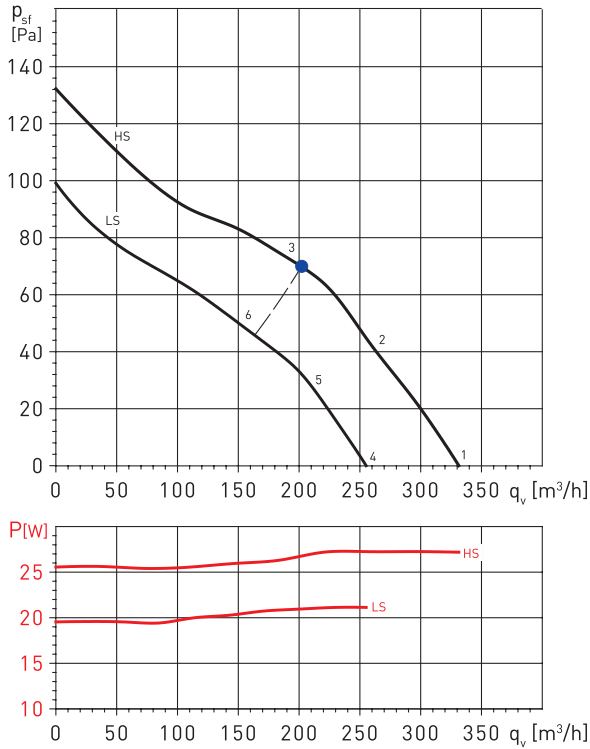

TD-500/150-160 SILENT 3V

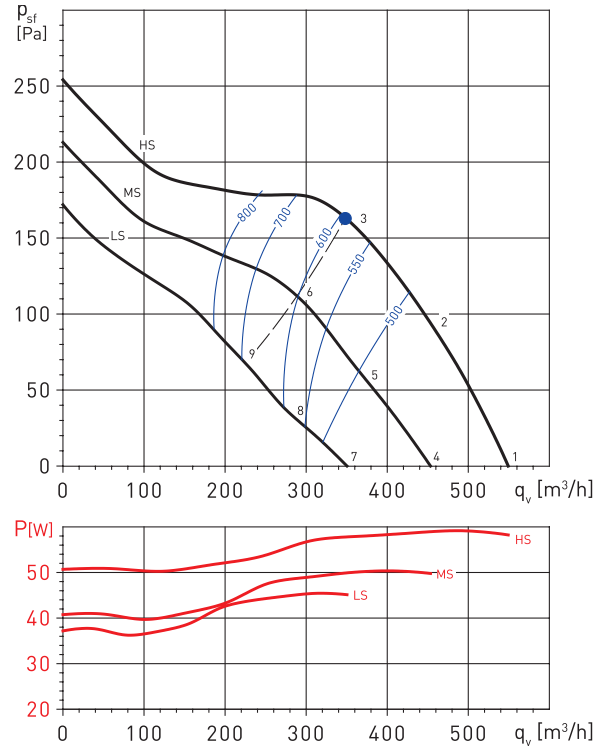

Sound power level spectrums in dB(A)

Working point		63	125	250	500	1.000	2.000	4.000	8.000	LwA
1	Inlet	22	26	41	51	51	43	36	29	54
	Outlet	27	28	42	50	51	44	36	28	55
	Break-out	19	23	34	40	38	30	20	14	43
2	Inlet	21	25	41	50	50	42	37	29	53
	Outlet	25	27	40	49	50	41	35	25	53
	Break-out	18	22	34	39	37	29	21	15	42
3	Inlet	23	30	45	53	51	46	40	31	56
	Outlet	23	31	44	51	49	43	38	31	54
	Break-out	20	27	38	42	39	32	24	17	45
4	Inlet	21	24	39	45	46	36	29	25	49
	Outlet	23	25	39	43	44	35	29	24	48
	Break-out	18	25	32	35	33	22	14	13	39
5	Inlet	21	25	38	44	46	35	31	25	49
	Outlet	22	26	37	42	43	33	29	24	47
	Break-out	18	25	31	34	34	22	16	13	38
6	Inlet	23	29	40	49	49	41	35	27	52
	Outlet	24	34	40	47	46	38	33	26	50
	Break-out	19	30	33	38	36	27	20	16	42

Sound power level spectrums in dB(A)

Working point		63	125	250	500	1.000	2.000	4.000	8.000	LwA
1	Inlet	25	35	52	59	59	58	52	46	64
	Outlet	38	38	56	59	58	54	49	43	63
	Break-out	18	28	41	40	43	41	33	28	47
2	Inlet	24	34	50	57	56	55	48	41	62
	Outlet	33	36	54	56	57	51	45	38	61
	Break-out	17	26	39	38	40	39	29	24	45
3	Inlet	25	35	49	59	56	54	48	41	62
	Outlet	26	36	53	59	57	49	44	28	62
	Break-out	18	28	38	40	40	37	29	24	45
4	Inlet	20	31	48	54	54	53	48	41	60
	Outlet	33	34	51	54	54	49	45	39	59
	Break-out	13	23	36	36	38	36	29	24	43
5	Inlet	19	29	45	52	52	51	43	36	57
	Outlet	28	31	49	52	53	46	40	34	57
	Break-out	12	21	34	33	35	34	24	19	40
6	Inlet	20	30	45	54	51	50	43	36	57
	Outlet	21	32	49	54	52	45	39	24	57
	Break-out	14	23	33	35	35	33	24	19	40
7	Inlet	15	25	42	49	49	48	42	36	54
	Outlet	28	28	46	49	48	44	39	33	54
	Break-out	8	18	31	30	33	31	23	18	38
8	Inlet	13	23	40	46	46	45	37	30	51
	Outlet	22	25	43	46	47	40	34	28	51
	Break-out	7	16	28	28	29	28	18	13	34
9	Inlet	15	25	39	49	46	44	38	31	52
	Outlet	16	26	43	49	47	39	34	18	52
	Break-out	8	17	28	30	29	27	19	13	35

IN-LINE MIXED FLOW DUCT FANS ULTRA-QUIET

TD-SILENT Series



PERFORMANCE CURVES

- q_v : Airflow in m^3/h .
- p_{sf} : Static pressure in Pa.
- Dry air at 20°C and 760 mmHg.
- Performance data in accordance with ISO 5801 and AMCA 210-99 Standards.
- SFP: Specific fan power in $W/m^3/s$ (blue curves).

HS : High speed
MS: Medium speed
LS: Low speed

TD-800/200 SILENT 3V

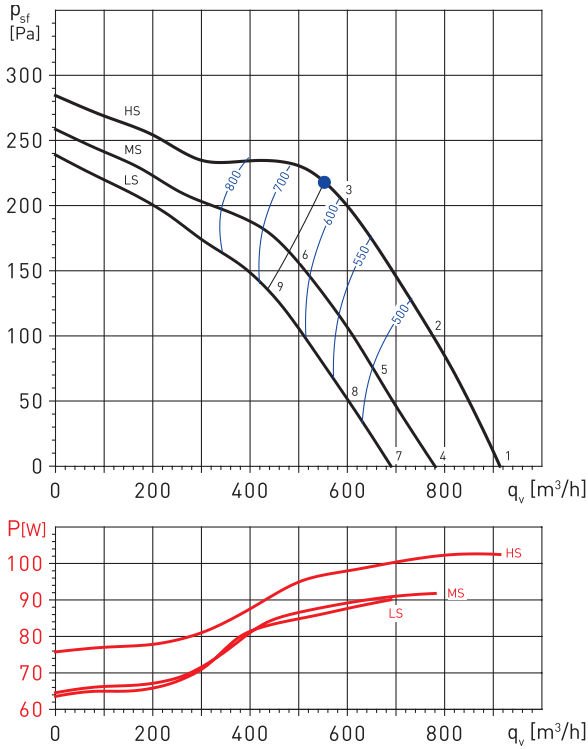

TD-1000/200 SILENT 3V

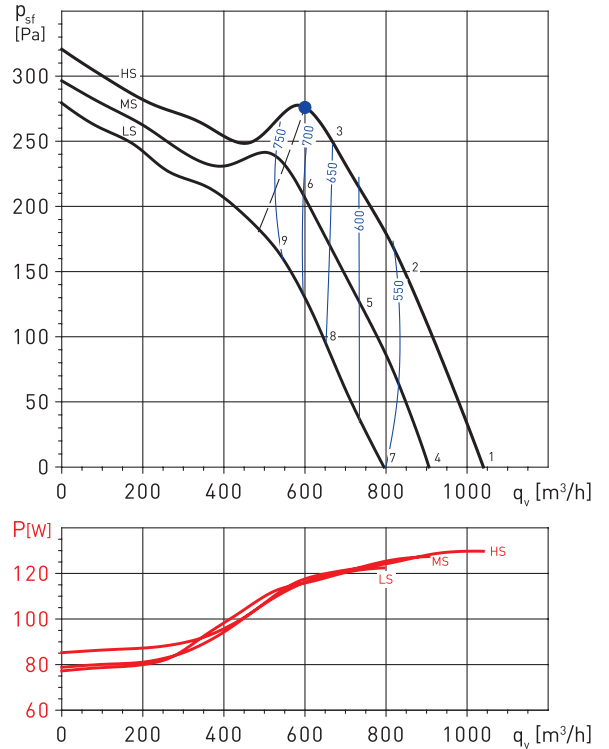

Sound power level spectrums in dB(A)

Working point		63	125	250	500	1.000	2.000	4.000	8.000	LwA
1	Inlet	27	40	49	60	61	62	57	51	66
	Outlet	44	46	51	60	64	63	60	53	69
	Break-out	18	34	35	42	45	41	32	24	48
2	Inlet	26	38	47	57	59	59	54	47	64
	Outlet	42	45	50	60	63	61	58	51	67
	Break-out	18	32	33	40	42	39	29	20	46
3	Inlet	26	40	50	60	61	60	56	50	66
	Outlet	33	40	51	60	61	59	55	49	65
	Break-out	18	33	36	43	44	40	30	23	48
4	Inlet	23	36	45	56	58	58	54	47	63
	Outlet	41	43	48	57	61	60	56	49	65
	Break-out	14	30	31	39	41	38	28	20	45
5	Inlet	23	35	43	54	56	56	51	44	61
	Outlet	39	41	47	56	59	58	54	47	63
	Break-out	14	29	29	36	39	36	25	17	42
6	Inlet	24	37	47	58	58	58	53	47	63
	Outlet	30	37	48	57	58	56	52	46	63
	Break-out	15	31	33	41	42	38	27	20	45
7	Inlet	20	34	43	53	55	55	51	44	60
	Outlet	38	40	45	54	58	57	54	47	62
	Break-out	12	28	29	36	38	35	25	17	42
8	Inlet	20	32	41	51	53	53	48	41	58
	Outlet	36	39	44	54	57	55	52	45	61
	Break-out	12	26	27	34	36	33	23	14	40
9	Inlet	22	35	45	56	56	56	51	45	61
	Outlet	28	35	46	55	56	54	50	44	60
	Break-out	13	29	31	38	39	35	25	18	43

Sound power level spectrums in dB(A)

Working point		63	125	250	500	1.000	2.000	4.000	8.000	LwA
1	Inlet	27	40	50	60	62	64	60	53	68
	Outlet	46	47	54	61	66	65	62	55	70
	Break-out	17	33	35	44	45	43	35	28	49
2	Inlet	27	38	49	59	61	62	56	49	66
	Outlet	41	43	52	59	63	61	57	50	67
	Break-out	16	31	34	42	43	40	31	24	47
3	Inlet	28	41	54	63	63	62	58	51	68
	Outlet	32	41	55	62	62	59	56	47	67
	Break-out	17	33	39	46	45	41	33	26	50
4	Inlet	26	39	49	59	61	63	58	51	67
	Outlet	44	46	53	59	64	64	61	53	69
	Break-out	15	32	34	43	43	41	33	26	48
5	Inlet	25	37	47	57	59	61	55	48	65
	Outlet	39	42	50	58	62	60	56	49	66
	Break-out	15	29	33	41	42	39	30	23	46
6	Inlet	26	39	52	61	61	61	56	50	67
	Outlet	31	39	54	60	61	58	54	46	65
	Break-out	16	32	37	45	43	39	31	24	48
7	Inlet	23	36	46	56	58	60	55	48	64
	Outlet	41	43	50	56	61	61	58	50	66
	Break-out	12	29	31	40	40	38	30	23	45
8	Inlet	23	34	45	54	57	58	52	45	62
	Outlet	37	39	47	55	59	57	53	46	63
	Break-out	12	26	30	38	39	36	27	20	43
9	Inlet	24	37	50	59	59	58	54	47	64
	Outlet	28	37	52	58	58	55	52	43	63
	Break-out	13	30	35	43	41	37	29	22	46

PERFORMANCE CURVES

- q_v : Airflow in m^3/h .
- p_{sf} : Static pressure in Pa.
- Dry air at 20°C and 760 mmHg.
- Performance data in accordance with ISO 5801 and AMCA 210-99 Standards.
- SFP: Specific fan power in $W/m^3/s$ (blue curves).

HS : High speed
MS : Medium speed
LS : Low speed

TD-1300/250 SILENT 3V

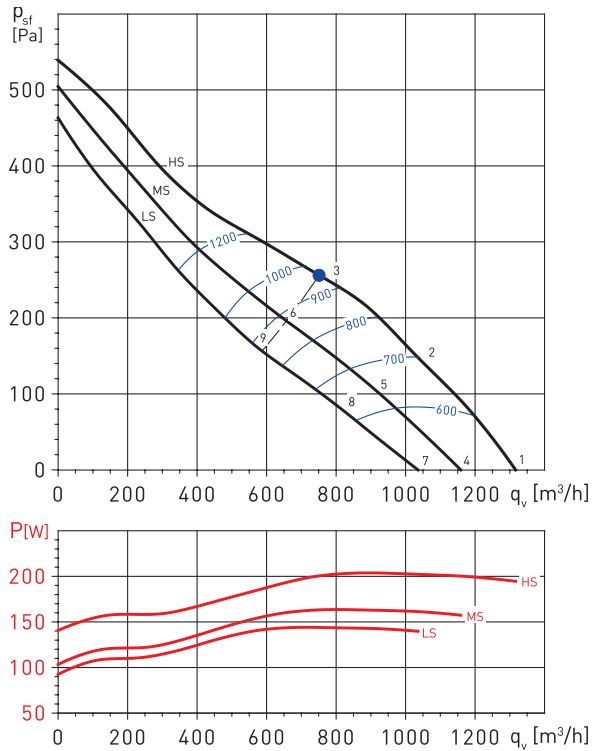

TD-2000/315 SILENT 3V

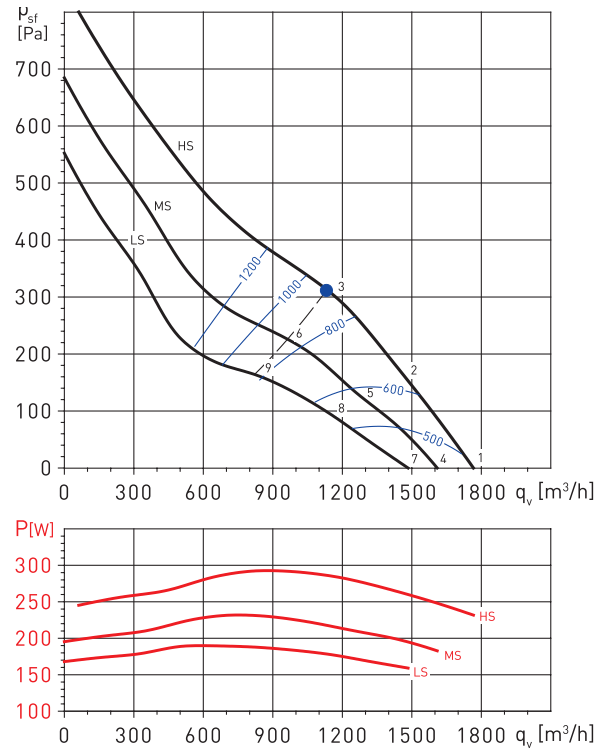

Sound power level spectrums in dB(A)

Working point		63	125	250	500	1.000	2.000	4.000	8.000	LwA
1	Inlet	30	42	60	59	62	61	58	52	67
	Outlet	33	45	60	68	72	65	54	48	74
	Break-out	26	31	46	42	55	48	39	38	57
2	Inlet	32	43	62	60	61	60	56	51	67
	Outlet	30	46	61	69	71	63	52	47	74
	Break-out	28	32	48	43	54	47	37	37	56
3	Inlet	36	47	63	60	58	58	55	48	67
	Outlet	32	51	62	69	67	60	51	44	72
	Break-out	32	36	49	43	51	45	36	34	54
4	Inlet	27	39	57	56	59	58	55	49	65
	Outlet	30	42	57	65	69	62	51	45	72
	Break-out	23	28	43	39	52	45	36	35	54
5	Inlet	29	40	59	57	58	57	53	48	64
	Outlet	27	43	58	66	68	60	49	44	71
	Break-out	25	29	45	40	51	44	34	34	53
6	Inlet	33	44	60	57	55	55	52	45	64
	Outlet	29	48	59	66	64	57	48	41	69
	Break-out	29	33	46	40	48	42	33	31	51
7	Inlet	25	37	55	54	57	56	53	47	63
	Outlet	28	40	55	63	67	60	49	43	70
	Break-out	21	26	41	37	50	43	34	33	52
8	Inlet	27	38	57	55	56	55	51	46	62
	Outlet	25	41	56	64	66	58	47	42	69
	Break-out	23	27	43	38	49	42	32	32	51
9	Inlet	31	42	58	55	53	53	50	43	62
	Outlet	27	46	57	64	62	55	46	39	67
	Break-out	27	31	44	38	46	40	31	29	49

Sound power level spectrums in dB(A)

Working point		63	125	250	500	1.000	2.000	4.000	8.000	LwA
1	Inlet	34	48	60	63	66	64	59	55	70
	Outlet	42	54	67	69	73	66	52	49	76
	Break-out	23	36	44	50	57	54	49	43	60
2	Inlet	34	49	63	62	65	64	60	55	70
	Outlet	38	55	66	67	73	65	51	49	75
	Break-out	23	37	47	49	56	54	50	43	60
3	Inlet	37	56	64	63	63	62	58	52	70
	Outlet	36	61	68	71	68	62	49	46	74
	Break-out	26	44	48	50	54	52	48	40	58
4	Inlet	32	46	58	61	64	62	57	53	69
	Outlet	40	52	65	67	71	64	50	47	74
	Break-out	21	34	42	48	55	52	47	41	58
5	Inlet	32	47	61	60	63	62	58	53	68
	Outlet	36	53	64	65	71	63	49	47	73
	Break-out	21	35	45	47	54	52	48	41	57
6	Inlet	34	53	61	60	60	59	55	49	67
	Outlet	33	58	65	68	65	59	46	43	71
	Break-out	23	41	45	47	51	49	45	37	55
7	Inlet	30	44	56	59	62	60	55	51	66
	Outlet	38	50	63	65	69	62	48	45	72
	Break-out	19	32	40	46	53	50	45	39	56
8	Inlet	29	44	58	57	60	59	55	50	65
	Outlet	33	50	61	62	68	60	46	44	70
	Break-out	18	32	42	44	51	49	45	38	54
9	Inlet	30	49	57	56	56	55	51	45	63
	Outlet	29	54	61	64	61	55	42	39	67
	Break-out	19	37	41	43	47	45	41	33	51

PRACTICAL EXAMPLES OF INSTALLING TD SILENT RANGE

TD Silent range offers one of the most versatile fan systems on the market today. Due to its flexibility it can be used in a multitude of small or medium fan installations. Especially in places where working people and the ventilation system works for many hours, in these cases the sound level becomes an essential element for comfort.

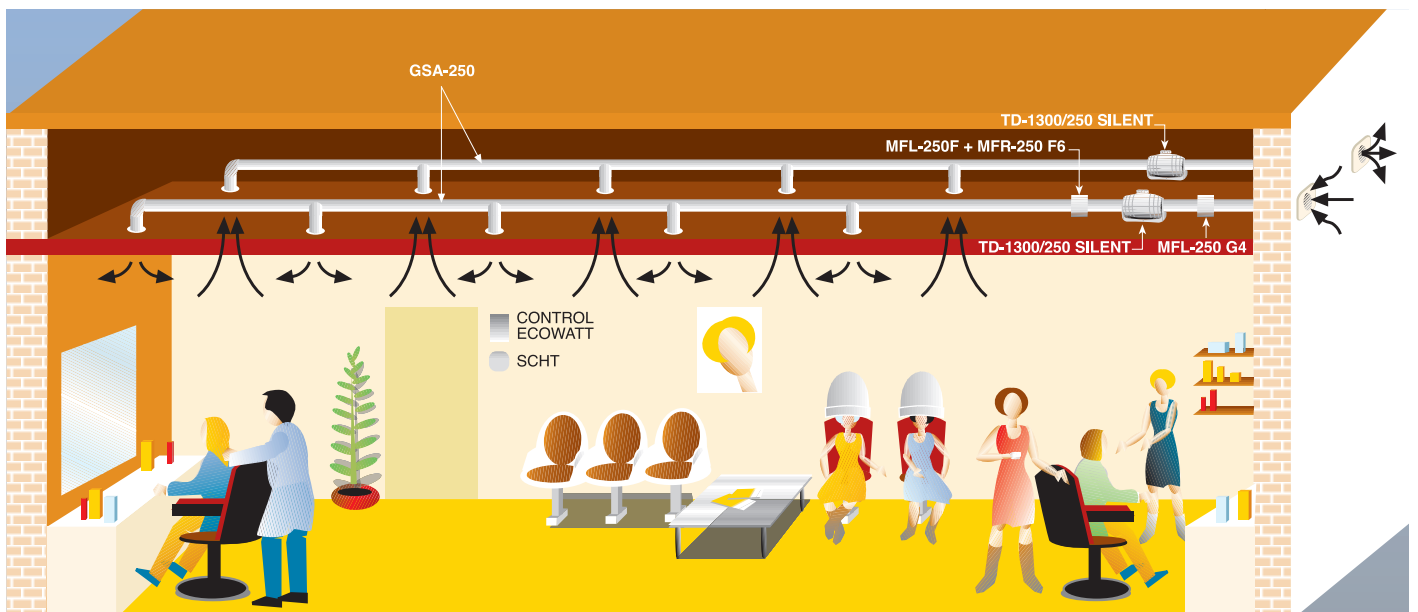
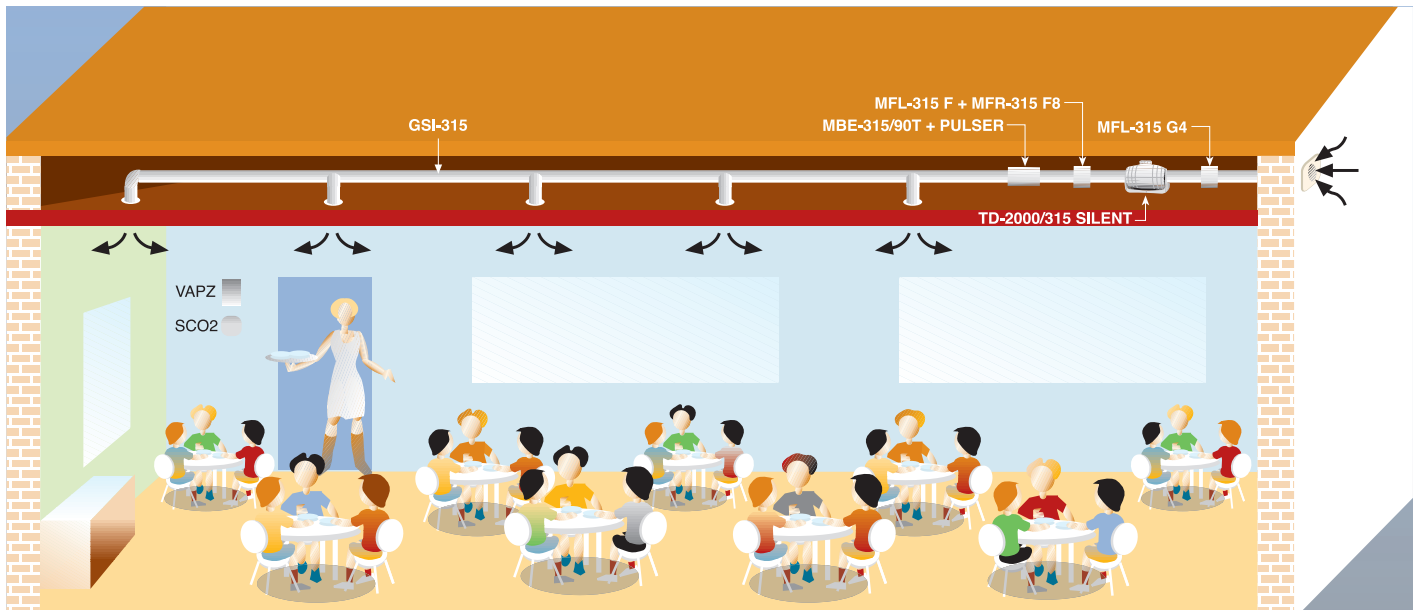

MOUNTING ACCESSORIES

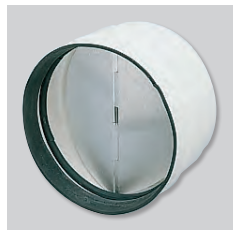

MCA-S

Non-return flaps to be installed at the fan discharge. They prevent heat leakages when the extractor is not operating.

MCA-S	TD-SILENT* range
MCA - 250 S	250/100
MCA - 350 S	350/125
MCA - 500/150 S	500/150
MCA - 500/160 S	500/160
MCA - 800-1000 S	800/200 - 1000/200

MCA	TD-SILENT* range
MCA - 1000	1300/250
MCA - 2000	2000/315

(* TD-1300/250 SILENT and TD-2000/315 SILENT models use non-return flaps MCA (see TD Series accessories).

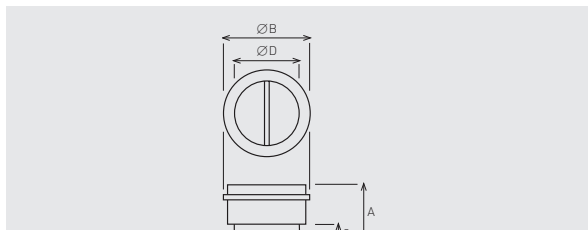

MCA-S	A	Ø B	C	Ø D
MCA - 250 S	107	109	31,5	94,5
MCA - 350 S	107	136	31,5	119,5
MCA - 500/150 S	121	163,5	35	147
MCA - 500/160 S	121	173,5	35	157
MCA - 800-1000 S	131,5	214	35	197,5

MCA	A	Ø B	C	Ø D
MCA - 1000	164	264,5	42	248
MCA - 2000	205	330	50	312



MAR-S

Rectangular duct adapters enable connection to rectangular ducting.

MAR-S	TD-SILENT* range	Nominal dimensions of the duct L X H (mm)
MAR - 250-350 S	250/100 - 350/125	224 x 140
MAR - 500 S	500/150	280 x 180
MAR - 800-1000 S	800/200-1000/200	315 x 200

MAR	TD-SILENT* range	Nominal dimensions of the duct L X H (mm)
MAR - 1000	1300/250	400 x 250
MAR - 2000	2000/315	500 x 315

(* TD-1300/250 SILENT and TD-2000/315 SILENT models use rectangular duct adapters MAR (see TD Series accessories).

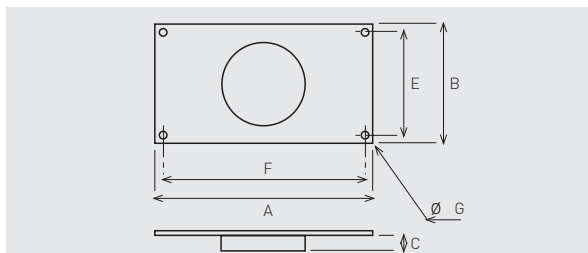

MAR-S	A	B	C	E	F	Ø G
MAR - 250-350 S	264	180	33,3	160	244	9
MAR - 500 S	320	220	37	200	300	9
MAR - 800-1000 S	355	240	37	220	335	9

MAR	A	B	C	E	F	Ø G
MAR - 1000	440	290	42	270	420	9
MAR - 2000	540	355	52	355	520	9



MRJ-S

Grilles mounted at the inlet or outlet of the fan, to prevent the entry of any foreign objects that could damage the fan.

MRJ-S	TD-SILENT* range
MRJ - 250-350 S	250/100 - 350/125
MRJ - 500/150-160 S	500/150 - 500/160
MRJ - 800-1000 S	800/200 - 1000/200

MRJ	TD-SILENT* range
MRJ - 1000	1300/250
MRJ - 2000	2000/315

(* TD-1300/250 SILENT and TD-2000/315 SILENT models use grilles MRJ (see TD Series accessories).

MOUNTING ACCESSORIES



MPC-S
Flow detectors designed to correctly measure pressures at the inlet of series TD devices with airflow straightener.

MPC-S	TD-SILENT* range
MPC-250 S	250/100
MPC-350 S	350/125
MPC-500/150 S	500/150 - 500/160
MPC-500/160 S	500/160
MPC-800-1000 S	800/200 - 1000/200

MPC	TD-SILENT* range
MPC-1000	1300/250
MPC-2000	2000/315

(* TD-1300/250 SILENT and TD-2000/315 SILENT models use flow detectors MPC (see TD Series accessories).

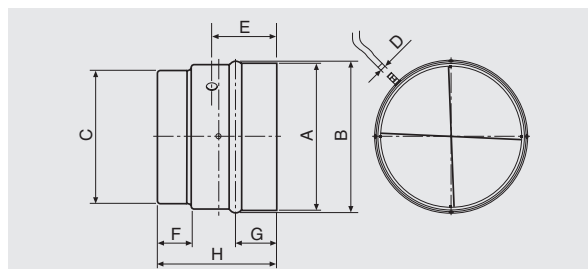

MPC-S	A	B	C	D	E	F	G	H
MPC-250 S	108	108,7	94,5	6	58	31,5	36,5	105,5
MPC-350 S	136	132	120	6	58	32	37	107
MPC-500/150 S	164	158	147	6	64	35	40	121
MPC-500/160 S	174	168	157	6	64	35	40	121
MPC-800-1000 S	214	208	198	6	70	35	40	132

MPC	A	B	C	D	E	F	G	H
MPC-1000	265	260	248	6	85	42	47	164
MPC-2000	329	318	312	6	106	50	55	204



MBR-S
Flanges allowing the coupling of TD-Silent fans in series.

MBR-S	Ø of the conduct
MBR-250-350 S	125
MBR-500 S	150
MBR-800-1000 S	200

(* TD-1300/250 SILENT and TD-2000/315 SILENT models use flange MBR (see TD Series accessories).

ELECTRICAL ACCESSORIES



REGUL 2
2 speed switch.



REB
Single phase electronic speed controller.



CONTROL ECOWATT AC/4A
Control element for demand controlled ventilation systems in public, commercial residential buildings it automatically modifies the fan speed to adapt it to the needs defined in the system, measured with sensors.



VAPZ
Electronic single phase regulator that controls the fan speed with a simple contact (presence detector) or an analogical input, 0-10 V or 4-20 mA (from CO₂ probe or relative sensor).



SC02-A
Ambient CO₂ and temperature sensor.

SC02-AD
Ambient CO₂ and temperature sensor, with display.

SCHT-AD
Ambient CO₂, temperature and relative humidity with display.



CPFL-S / CPFL-E
Presence detector for ceiling mount, sensitive to infrared radiation by bodies in movement, with a 360° detecting angle. Power supply: 1-230 V.



TDP-S/TDP-D/TDP-PI
Pressure sensor. Enables you to control the pressure in the fan inlet. Pressure range: 0-2500 Pa. Output signal: 0-10V/4-20 mA.



REMP
Motorised damper, opens proportionately and is controlled by the BEAS control module. Power supply: 24 VAC or 24 VD, depending on the models.